



O-Ring Reference Guide



www.bayseal.com
1.800.273.SEAL (7325)

Bay Seal Company O-Ring Reference Guide

TABLE OF CONTENTS

Introduction	1
What is an O-ring?	1
How are O-rings made?	1
Standard O-ring and Seal Elastomers	2
Comparison of properties of commonly used elastomers	2
How are O-rings sized?	3
How do I specify and order an O-ring?	3
What is Durometer?	4
What is Compression Set?	4
What is Extrusion?	4
What is Vacuum Technology?	5
Permeation	5
Outgassing	5
Trapped Gas	5
What is Vacuum Pressure?	6
What is an NW/ISO-type centering ring assembly?	6
What is a spliced O-ring?	6
What is ID Stretch and OD interference?	7
What is Reduction in Cross-Section?	7
Face Seal Gland Design	8
Static Seal Gland Design	9
Industrial Reciprocating Seal Design	10
Full Dovetail Groove Design	11
Half Dovetail Groove Design	11
AS568 O-ring size chart	12
JIS B2404 O-ring size chart	22
Fraction, Decimal, and Millimeter Conversion Chart	24
Chemical Compatibility Table	25
Pressure Conversion Table	49
Temperature Conversion Table	49
Common Seal Failures	50
Standard Glossary Terms	52

WARNING



Improper selection and use of any information described herein can cause death, personal injury and/or property damage.

The user of this guide should analyze all aspects of an application(s) and review the information of the product or system within the current product catalog. The information within this guide has been researched and tested, but it is the users responsibility to conduct their own analysis and testing due to the operating and environmental conditions that may vary. The user is solely responsible for making the final selection of any and all products regarding an application(s).

Introduction

Bay Seal Company has compiled this O-ring reference guide to provide a quick and easy source for all your basic O-ring sizing and material information needs. Also included within this guide are gland design guidelines, elastomer/compound information, and a complete listing of AS568 and JIS O-ring size references.

Although this O-ring reference guide is extensive and informative, please rely on the expertise of Bay Seal Company to assist you with all of your sealing inquiries. Remember, the suggested guidelines are for nominal conditions, but minimum and maximum conditions should always be considered when choosing the correct sealing solution. It is highly recommended that the end users conduct their own evaluations and tests when choosing a seal for any application.

What is an O-ring?

An O-ring is a torus, or doughnut-shaped object, generally made from an elastomer, though are made in other plastic materials, and in metals, both hollow and solid. They are used primarily for sealing.

An O-ring is usually needed for closing off a passageway and prevents an unwanted escape or loss of a fluid. The seal consists of an O-ring installed in a gland, which is usually a circular design. The elastomeric material has a cross section that is also a virtual circle. The gland is the cavity (usually machined metal) into which the O-ring is placed. The combination of these two elements comprises an O-ring seal.

How are O-rings made?

The production of elastomeric O-rings involves several steps. This diagram is a basic schematic of the process flow from monomers to O-rings.

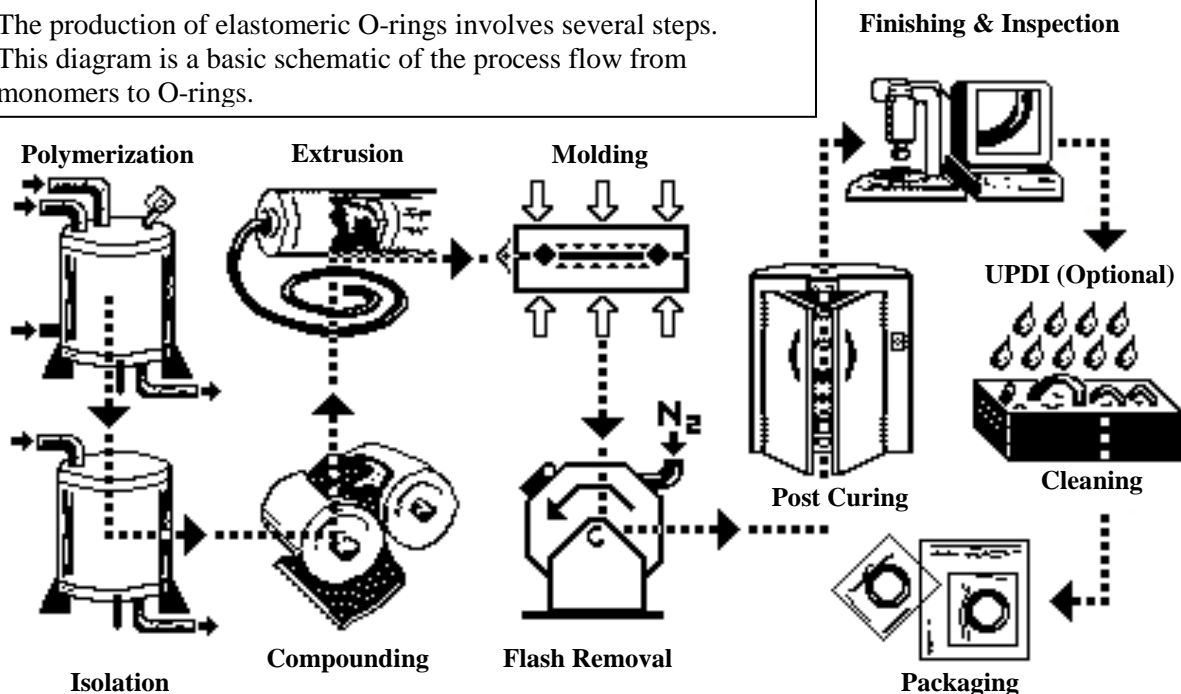

Standard O-Ring and Seal Elastomers

Elastomer & Temperature	Applications	Use With These Fluids	Do Not Use With These Fluids
Ethylene Propylene (EPDM) -57°C to +149°C (-70°F to +300°F)	Ethylene Propylene has excellent ozone and chemical resistance characteristics. Generally used in automotive brake systems.	Brake fluids, refrigerants, steam	Petroleum oils, diester lubricants
Fluoroelastomer (FKM) -26°C to +205°C (-15°F to +400°F)	Featuring excellent resistance to petroleum products and solvents, with good high temperature and low compression set characteristics. For use with wide chemical exposure situations, and with low gas permeability, it is also suited for hard vacuum service.	Petroleum oils, gasoline, transmission fluid	Acetone, H ₂ S, hot water, amines
Fluorosilicone (FVMQ) -73°C to +190°C (-100°F to +375°F)	Fluorosilicone combines the good high and low temperature stability of silicone with the fuel, oil, and solvent resistance of fluorocarbon.	Petroleum oils, gasoline	Acetone, ethyl acetate
Nitrile (Buna-N) (NBR) -34°C to +121°C (-30°F to +250°F) Nitrile (Low-Temp) -55°C to +107°C (-65°F to +225°F)	Nitrile combines excellent resistance to petroleum based oils and fuels, silicone greases, hydraulic fluids, water and alcohols. It has a good balance of working properties such as low compression set, high tensile strength, and high abrasion resistance, combined with a low cost.	Petroleum oils, water, hydraulic oils	Brake fluid, ketones, phosphate esters, H ₂ S
Perfluoroelastomer (FFKM) -26°C to +316°C (-15°F to +600°F)	Perfluoroelastomers possess outstanding resistance to a broad range of chemicals, excellent heat resistance, and overwhelming outgassing performance within vacuum environments.	Most chemicals	---
Silicone (VMQ) -54°C to +232°C (-65°F to +450°F)	Silicone elastomer is resistant to high, dry heat, in primarily static applications. It has low compression set characteristics and a wide temperature range.	Dry heat, alcohol, vegetable oil	Petroleum oils & fuels

Comparison of properties of Commonly Used Elastomers

	Abrasion Resistance	Acid Resistance	Chemical Resistance	Cold Resistance	Dynamic Properties	Electrical Properties	Flame Resistance	Heat Resistance	Impermeability	Oil Resistance	Ozone Resistance	Set Resistance	Tear Resistance	Tensile Strength	Water/Steam Resistance	Weather Resistance
P - POOR F - FAIR G - GOOD E - EXCELLENT																
Ethylene Propylene (EPDM)	GE	G	E	GE	GE	G	P	E	G	P	E	GE	GE	GE	E	E
Fluoroelastomer (FKM)	G	E	E	FP	GE	F	E	E	G	E	E	GE	F	GE	FG	E
Fluorosilicone (FVMQ)	P	FG	E	GE	P	E	G	E	P	G	E	GE	P	F	F	E
Nitrile or Buna-N (NBR)	G	F	FG	G	GE	F	P	G	G	E	P	GE	FG	GE	FG	F
Perfluoroelastomer (FFKM)	P	E	E	PF	F	E	E	E	G	E	E	G	PF	FG	GE	E
Silicone (VMQ)	P	FG	GE	E	P	E	F	E	P	PG	E	GE	P	P	F	E



How are O-rings sized?

O-ring seals have been standardized under the basic industrial standard dimensions of AS568 (Pages 12 through 21), an Aerospace Standard published by the Society of Automotive Engineers, and a multitude of military standards; AN6227 and MS28775 for general use; M25988, M83248, MS9020, MS9355, and MS29512 for straight-thread tube fittings; and MS28900 for electrical connectors.

AN6227 is an Air Force-Navy Aeronautical Standard that covers 88 sizes of AS568. MS28775 is the basic standard on which AS568 was developed. M25988, M83248, MS9020, MS9355, and MS29512 cover 31 O-rings of slightly larger diameter cross-sections to be used for sealing straight-thread tube fittings. These O-rings are equivalent to dash numbers 901 through 932 of AS568. They are used in gland designs specified by military standards MS16142, MS33649, and MS33656 for tube fittings.

The Japanese International Standard (JIS B2404) is located on pages 22 through 24.

Other sizes, including metric, please contact Bay Seal Company.

How do I specify and order an O-ring?

If you know the particular O-ring that will help with your application, and you do not need the assistance from Bay Seal Company, please remember a few important measurements when ordering your desired O-ring.

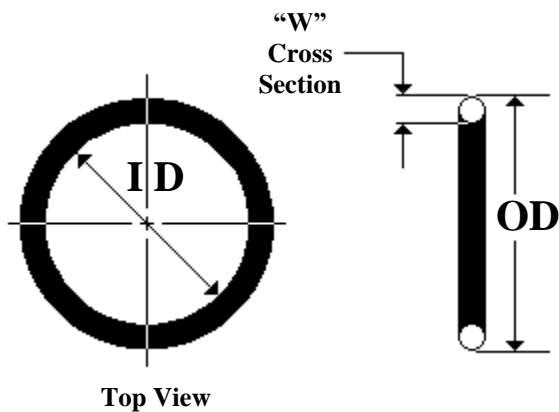

Every O-ring order should be accompanied with the standard size number, the desired compound, and durometer.

Or

The I.D. (Inside Diameter) or O.D. (Outer Diameter), the W (Cross Section), the desired compound, and durometer.

Please Note: If you are unable to find the size you need within the charts located on pages 12 through 24, contact Bay Seal Company at (800) 273-SEAL (7325) to assist you.

Bay Seal Company offers many solutions that are non-standard and can assist you further with you sealing solutions. Other such solutions may include Spliced O-rings, Lathe Cuts, Custom Molded Parts, Rubber to Metal Bonding, and so much more. Contact us for all your sealing needs.

What is durometer?

Durometer is the international standard for the hardness measurement of rubber, plastic, and other nonmetallic materials. The Shore A Durometer measuring device consists of a needle on a spring that measures how far the needle indents the material. This device is an excellent tool for measuring and determining if an elastomeric material is cured properly. Simply stated, the lower the number, the softer the material. A vast majority of O-rings have a Shore A Durometer between 60 and 75. Many people use the durometer measurement as a criterion for determining the material they require.

What is compression set?

Compression Set is the resistance of material to permanent deformation. ASTM D395 is a test in which an O-ring is compressed to 75% of its original thickness, kept at that compression for 22 hours at 158°F, then released and allowed to return to its original thickness. The conclusion of this test is the percentage of the original compression (25%) which is not recovered.

Calculations:

Compression Squeeze
 Cross Section – Gland Height

Compression Ratio
 $\frac{\text{Compression Squeeze}}{\text{Cross Section}} \times 100$

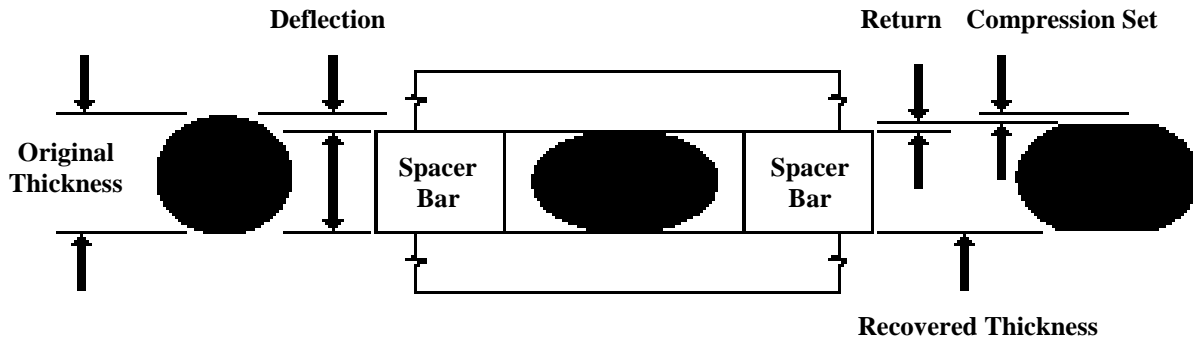

What is extrusion?

Extrusion is the distortion, under pressure, of a portion of an O-ring into the clearance between two mating metal parts. In order to reduce extrusion, the extrusion gap must be reduced, or the material durometer must be increased, or a combination of both.

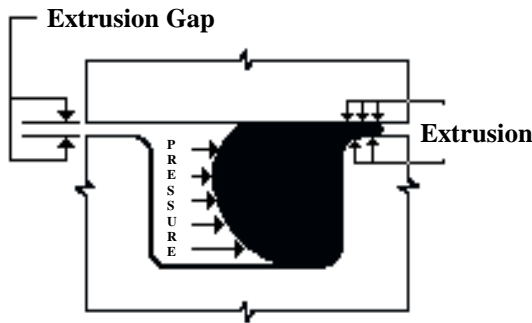

Maximum Recommended Extrusion Gap in Inches (mm)				
Pressure (PSI)	Elastomer Hardness (Durometer)			
	60	70	80	90
500	.010 (.25)	.015 (.38)	.020 (.51)	.025 (.64)
750	.005 (.13)	.011 (.28)	.016 (.41)	.023 (.58)
1000	.002 (.05)	.008 (.20)	.012 (.30)	.018 (.46)
1250	.001 (.02)	.004 (.10)	.009 (.23)	.015 (.38)
1500	N/A	.002 (.05)	.007 (.18)	.012 (.30)

What is vacuum technology?

A vacuum is a space from which air and other gases have been virtually removed. Permeation, Outgassing, and Trapped Gas are three primary sources of residual gas contaminants from elastomeric seals.

Permeation is the volumetric flow rate of a gas under steady-state conditions through a unit surface area of unit thickness at unit pressure difference. Permeability is a fundamental property of an elastomer. The solubility and diffusion of a gas through an elastomer affects the pump-down time as well as the vacuum achieved in a vacuum seal.

In General:

- Swelling decreases permeation rate.
- High pressures decrease permeation rate (reduction of free volume).
- Higher temperatures increase diffusion rate and permeation rate.
- Inorganic fillers eliminate diffusive passages and lower permeability.
- Larger molecules of gas lower the diffusion rate.

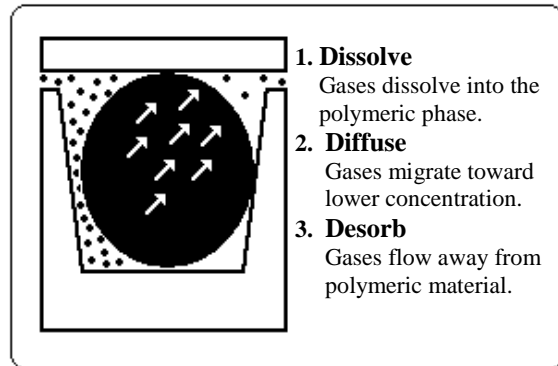

Outgassing is the release of volatile materials as an elastomer is heated, which affects vacuum performance. Many traditional seal materials contain small amounts of low-molecular-weight plasticizers, or process aids, that can volatilize under vacuum conditions. To significantly reduce outgassing, you may Heat an O-ring for several hours at 100°C and/or Vacuum bake an O-ring.

Trapped Gas refers to the release of gas trapped by the elastomer in the groove (especially dovetail grooves), which can slowly leak out over time.

Gas Trapped by Seal Design

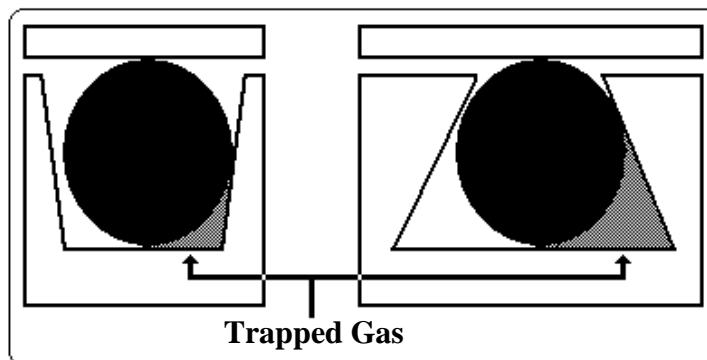

What is vacuum pressure?

Vacuum is usually specified in terms of absolute pressure, hence, the lower the pressure, the higher the vacuum. Zero pressure would represent the ultimate vacuum, in which there are no gas molecules present in the volume under consideration. This situation is virtually impossible to achieve in practice.

Normal atmospheric pressure represents zero vacuum and is usually expressed in terms of the height of a column of mercury that it will support. A pressure conversion table is located on page 49.

Conversion Formulas:

Atmosphere x 1012.95 = millibar
 Atmosphere x 760 = Torr
 Atmosphere x 14.696 = lb/in² (PSI)
 Atmosphere x 29.9213 = in Hg

What is an NW/ISO-type centering ring assembly?

Centering ring assemblies are necessary, when using NW/ISO flanges, to maintain a reliable and effective vacuum seal. The centering ring component is usually manufactured out of stainless steel or aluminum, but is not necessarily limited to those alloys when certain application conditions warrant other metals. The seal component can be any elastomeric compound, but are usually either a fluoroelastomer (FKM) or perfluoroelastomer (FFKM).

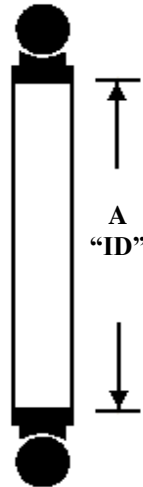

Centering Ring Assembly		
Flange	O-Ring Size	A
NW-10	NW10X	0.456
NW-16	NW16X	0.625
NW-25	NW25X	0.964
NW-40	NW40X	1.560
NW-50	NW50X	1.967
ISO-63	ISO63X	2.630
ISO-80	ISO80X	3.140
ISO-100	ISO100X	3.890
ISO-160	ISO160X	5.900
ISO-200	ISO200X	8.260
ISO-250	ISO250X	10.140
ISO-320	ISO320X	12.180

X - This identification call-out should be the compound abbreviation. Nitrile = NBR, Fluoroelastomer = FKM, Perfluoroelastomer = FFKM (Call Bay Seal Company for assistance with specific manufacturer's compounds)

What is a spliced O-ring?

A spliced O-ring is made from an extruded cord and then vulcanized to form the O-ring size of need. Spliced O-rings are viable solutions when standard O-rings cannot be used within an application. The procedure of splicing an O-ring includes cutting an extruded elastomer to the desired length, making sure both ends are evenly cut and properly cleaned, applying uncured adhesive material to both ends, and then inserting into a splicing mold where consistent pressure and temperature are applied (pressure, temperature, and time varies with compound and cross section of the elastomer.)

Bay Seal Company has perfected this procedure and does provide this service to all of our customers. Please contact Bay Seal Company for information regarding spliced O-rings.

What is ID stretch and OD interference?

The ID and OD of an O-ring should be chosen to also minimize the chance for installation damage and wear during use. Following are some rules necessary for O-ring choice:

- **Piston Type Seals:** ID should be slightly smaller than the gland diameter, so that the installed O-ring is slightly stretched.
- **Rod Type Seals:** OD should be slightly larger than the gland diameter, so that there is always some interference with the installed O-ring.
- **External Pressure Face Seals:** ID should be slightly smaller than the inner diameter of the groove, so when pressure is applied, the O-ring is already in position as a result of the pressure.
- **Internal Pressure Face Seals:** OD should be slightly larger than the outer diameter of the groove, so when pressure is applied, the O-ring is already in position as a result of the pressure.

<u>Calculations:</u>		
Piston Type Seal (Stretch)		
Stretch = $\frac{\text{Gland} - \text{ID}}{\text{ID}}$	Max = 5%	Min = 0%
Rod Type Seal (Interference)		
Interference = $\frac{\text{OD} - \text{Gland}}{\text{OD}}$	Max = 2%	Min = 0%
External Pressure Face Type Seal (Stretch)		
Stretch = $\frac{\text{In} - \text{ID}}{\text{ID}}$	Max = 5%	Min = 0%
Internal Pressure Face Type Seal (Interference)		
Interference = $\frac{\text{OD} - \text{Out}}{\text{OD}}$	Max = 3%	Min = 0%

Cross Section Detail

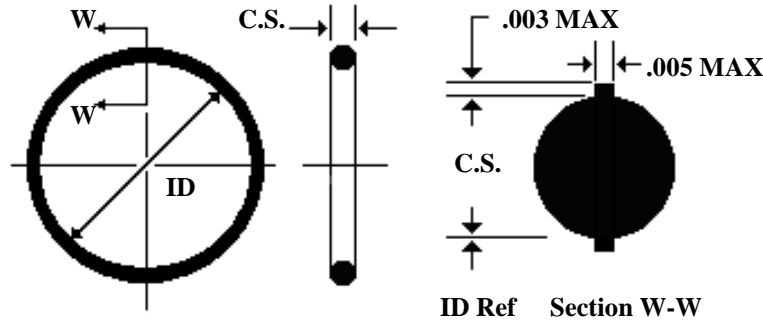

What is reduction in cross section?

Elastomers are not compressible materials. So, if the ID of an O-Ring is “stretched”, the cross section will decrease. Please refer to the following table for resulting ID stretch. The selected cross section should be used for all compression and glad fill calculations for piston type and external pressure face seals.

AS568 Series	Original Cross Section (in/ mm)	Reduced Cross Section at % of ID Stretch (in / mm)				
		1%	2%	3%	4%	5%
-0xx	0.070 in	.069	.069	.068	.068	.068
-1xx	0.103 in	.102	.101	.100	.100	.100
-2xx	0.139 in	.138	.137	.136	.135	.134
-3xx	0.210 in	.208	.206	.205	.204	.203
-4xx	0.275 in	.272	.270	.268	.267	.266
-0xx	1.78 mm	1.76	1.75	1.74	1.73	1.72
-1xx	2.62 mm	2.59	2.57	2.56	2.55	2.53
-2xx	3.53 mm	3.49	3.47	3.44	3.43	3.41
-3xx	5.33 mm	5.28	5.24	5.20	5.18	5.15
-4xx	6.99 mm	6.92	6.87	6.82	6.79	6.75

Face Seal Gland Design Chart

Side Wall Angle is to allow for releasing of molded parts. Sidewalls of machined parts should be vertical.

Groove OD (Ho)
 For Internal Pressure:
 Dimension the groove by it's OD and width.
 Ho=Mean OD of O-ring.
 Tol=-1% of Mean OD
 not > -.060

Groove ID (Hi)
 For External Pressure:
 Dimension the groove by it's ID and width.
 Hi=Mean ID of O-ring.
 Tol=+1% of Mean ID
 Not > +.060

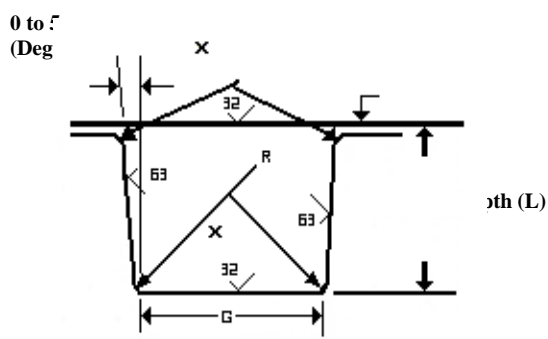
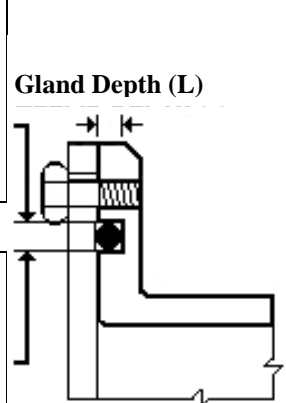

X=16 RMS when sealing gas or vacuum.
 X=16 RMS for all dynamic surfaces.

Face Seal Gland

These dimensions are intended primarily for face type seals and low temperature applications.

O-Ring Size No.	W O-Ring Cross Section		L Gland Depth	Squeeze		G Groove Width		R Groove Radius
	Nominal	Actual		Actual	%	Liquids	Vacuum and Gases	
	-004 To -050	1/16	.070 ± .003	.050 to .054	.013 to .023	19 to 32	.101 to .107	.084 to .089
-102 To -178	3/32	.103 ± .003	.074 to .080	.020 to .032	20 to 30	.136 to .142	.120 to .125	.005 to .015
-201 To -284	1/8	.139 ± .004	.101 to .107	.028 to .042	20 to 30	.177 to .187	.158 to .164	.010 to .025
-309 To -395	3/16	.210 ± .005	.152 to .162	.043 to .063	21 to 30	.270 to .290	.239 to .244	.020 to .035
-425 to -475	1/4	.275 ± .006	.201 to .211	.058 to .080	21 to 29	.342 to .362	.309 to .314	.020 to .035
Special	3/8	.375 ± .007	.276 to .286	.082 to .106	22 to 28	.475 to .485	.419 to .424	.030 to .045
Special	1/2	.500 ± .008	.370 to .380	.112 to .138	22 to 27	.638 to .645	.560 to .565	.030 to .045

Static Seal Gland Design Chart

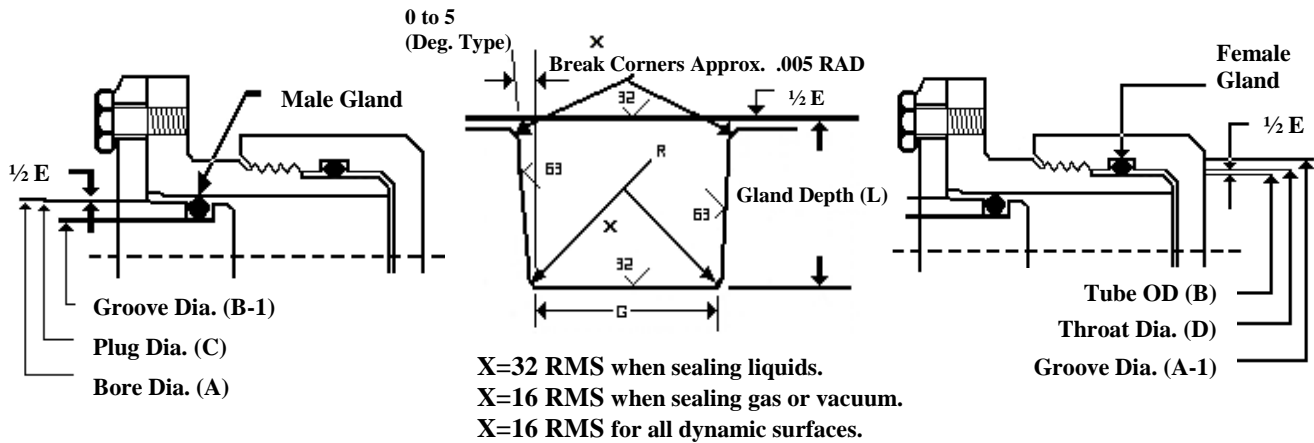

Static Gland - Male

Static Gland - Female

O-ring Size No.	W Cross Section		L Gland Depth	Squeeze		E (a, c) Diametral Clearance	G Groove Width	R Groove Radius	Eccentricity Max. (b)
	Nominal	Actual		Actual	%				
-004 to -050	1/16	0.070 ± .003	0.050 to 0.052	0.015 to 0.023	22 to 32	0.002 to 0.005	0.093 to 0.098	0.005 to 0.015	0.002
-102 to -178	3/32	0.103 ± .003	0.081 to 0.083	0.017 to 0.025	17 to 24	0.002 to 0.005	0.140 to 0.145	0.005 to 0.015	0.002
-201 to -284	1/8	0.139 ± .004	0.111 to 0.113	0.222 to 0.032	16 to 23	0.003 to 0.006	0.187 to 0.192	0.010 to 0.025	0.003
-309 to -395	3/16	0.210 ± .005	0.170 to 0.173	0.032 to 0.045	15 to 21	0.003 to 0.006	0.281 to 0.286	0.020 to 0.035	0.004
-425 to -475	1/4	0.275 ± .006	0.226 to 0.229	0.040 to 0.055	15 to 20	0.004 to 0.007	0.375 to 0.38	0.020 to 0.035	0.005

- (a) Clearance gap must be held to a minimum consistent with design requirements for temperature range variation.
- (b) Total Indicator reading between groove and adjacent bearing surface.
- (c) Reduce maximum diametral clearance 50% when using silicone or Fluorosilicone O-rings.

Dovetail Groove Design Charts

Cross Sectional Dimensions

Full Dovetail Groove Detail

For dovetail grooves, match the centerline of the groove with the centerline of the O-ring. Gland width is to sharp edge of groove.

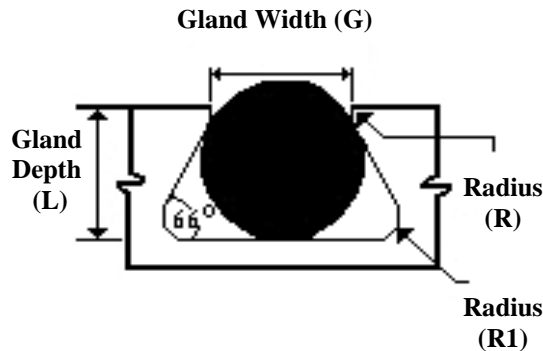

AS568A Series	O-Ring Cross Section		Gland Width (G)	Squeeze %	Gland Depth (L)	Gland Corner Radii	
	Actual	Tol +/-				(R)	(R1)
-004 To -050	0.070	0.003	.057 To .061	23	.053 To .055	0.005	1/64
-102 To -178	0.103	0.003	.083 To .087	21	.081 To .083	0.010	1/64
-201 To -284	0.139	0.004	.113 To .117	20	.111 To .113	0.010	1/32
-309 To -395	0.210	0.005	.171 To .175	18	.171 To .173	0.015	1/32
-425 To -475	0.275	0.006	.231 To .235	16	.231 To .234	0.015	1/16

AS568A Series	O-Ring Cross Section		Gland Width (G)	Squeeze %	Gland Depth (L)	Gland Corner Radii	
	Actual	Tol +/-				(R)	(R1)
-004 To -050	0.070	0.003	.064 To .066	23	.053 To .055	0.005	1/64
-102 To -178	0.103	0.003	.095 To .097	19	.083 To .085	0.010	1/64
-201 To -284	0.139	0.004	.124 To .128	18	.113 To .115	0.010	1/32
-309 To -395	0.210	0.005	.190 To .193	17	.173 To .176	0.015	1/32
-425 To -475	0.275	0.006	.255 To .257	15	.234 To .238	0.015	1/16

Half Dovetail Groove Detail

For dovetail grooves, match the centerline of the groove with the centerline of the O-ring. Gland width is to sharp edge of groove.

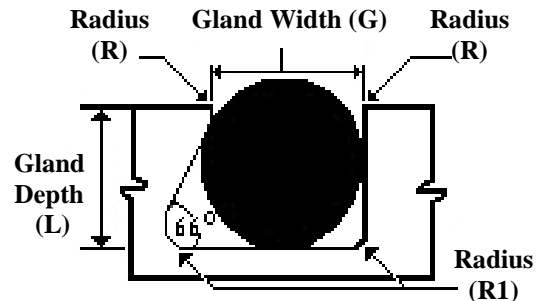

Industrial Reciprocating Seal Design Chart

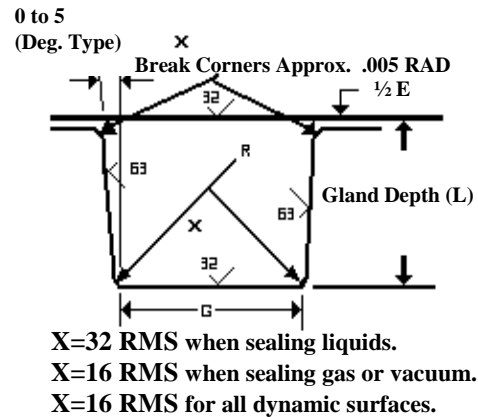
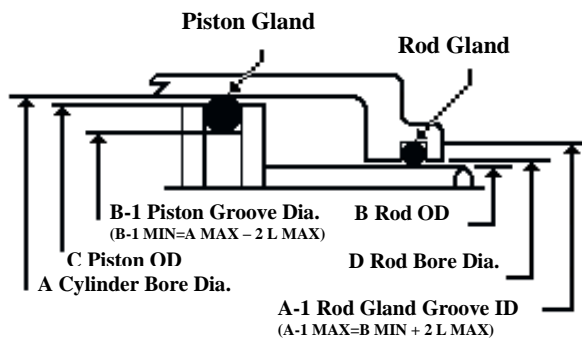

O-Ring Size No.	W O-Ring Cross Section		L Gland Depth	Squeeze		E (a) Diametral Clearance	R Groove Radius	Max. Eccentricity (b)
	Nominal	Actual		Actual	%			
	-006 to -012	1/16	.070 ± .003	.055 to .057	.010 to .018	15 to 25	.002 to .005	
-014 to -116	3/32	.103 ± .003	.088 to .090	.010 to .018	10 to 17	.002 to .005	.005 to .015	.002
-201 to -222	1/8	.139 ± .004	.121 to .123	.012 to .022	9 to 16	.003 to .006	.010 to .025	.003
-309 to -349	3/16	.210 ± .005	.185 to .188	.017 to .030	8 to 14	.003 to .006	.020 to .035	.004
-425 to -460	1/4	.275 ± .006	.237 to .240	.029 to .044	11 to 16	.004 to .007	.020 to .035	.005

(a) Clearance (extrusion gap) must be held to a minimum consistent with design requirements for temperature range variation

(b) Total indicator reading between groove and adjacent bearing surface.

AS568 O-Ring Sizes

1	2			3				4	5				
Size Only	Nominal Size			Standard O-Ring Size (Units are in inches)					Metric O-Ring Size (Units are in Millimeters)				
	(Inches)			Actual (b) Per AS 568A					Actual (b) Per AS 568A				
AS 568A Uniform Dash No.	(Ref. Only)				Tol.	(Ref. Only)			Basic Volume		Tol.		
	I.D.	O.D.	W.	ID	±	W	±	Cu. In.	I.D.	±	W	±	
-001	1/32	3/32	1/32	.029	.004	.040	.003	.0003	0.74	0.10	1.02	0.08	
-002	3/64	9/64	3/64	.042	.004	.050	.003	.0006	1.07	0.10	1.27	0.08	
-003	1/16	3/16	1/16	.056	.004	.060	.003	.0010	1.42	0.10	1.52	0.08	
-004	5/64	13/64	1/16	.070	.005	.070	.003	.0017	1.78	0.13	1.78	0.08	
-005	3/32	7/32	1/16	.101	.005	.070	.003	.0021	2.57	0.13	1.78	0.08	
-006	1/8	1/4	1/16	.114	.005	.070	.003	.0022	2.90	0.13	1.78	0.08	
-007	5/32	9/32	1/16	.145	.005	.070	.003	.0026	3.68	0.13	1.78	0.08	
-008	3/16	5/16	1/16	.176	.005	.070	.003	.0030	4.47	0.13	1.78	0.08	
-009	7/32	11/32	1/16	.208	.005	.070	.003	.0034	5.28	0.13	1.78	0.08	
-010	1/4	3/8	1/16	.239	.005	.070	.003	.0037	6.07	0.13	1.78	0.08	
-011	5/16	7/16	1/16	.301	.005	.070	.003	.0045	7.65	0.13	1.78	0.08	
-012	3/8	1/2	1/16	.364	.005	.070	.003	.0052	9.25	0.13	1.78	0.08	
-013	7/16	9/16	1/16	.426	.005	.070	.003	.0060	10.82	0.13	1.78	0.08	
-014	1/2	5/8	1/16	.489	.005	.070	.003	.0068	12.42	0.13	1.78	0.08	
-015	9/16	11/16	1/16	.551	.007	.070	.003	.0075	14.00	0.18	1.78	0.08	
-016	5/8	3/4	1/16	.614	.009	.070	.003	.0083	15.60	0.23	1.78	0.08	
-017	11/16	13/16	1/16	.676	.009	.070	.003	.0090	17.17	0.23	1.78	0.08	
-018	3/4	7/8	1/16	.739	.009	.070	.003	.0098	18.77	0.23	1.78	0.08	
-019	13/16	15/16	1/16	.801	.009	.070	.003	.0105	20.35	0.23	1.78	0.08	
-020	7/8	1	1/16	.864	.009	.070	.003	.0113	21.95	0.23	1.78	0.08	
-021	15/16	1 1/16	1/16	.926	.009	.070	.003	.0120	23.52	0.23	1.78	0.08	
-022	1	1 1/8	1/16	.989	.010	.070	.003	.0128	25.12	0.25	1.78	0.08	
-023	1 1/16	1 3/16	1/16	1.051	.010	.070	.003	.0136	26.70	0.25	1.78	0.08	
-024	1 1/8	1 1/4	1/16	1.114	.010	.070	.003	.0143	28.30	0.25	1.78	0.08	
-025	1 3/16	1 5/16	1/16	1.176	.011	.070	.003	.0151	29.87	0.28	1.78	0.08	
-026	1 1/4	1 3/8	1/16	1.239	.011	.070	.003	.0158	31.47	0.28	1.78	0.08	
-027	1 5/16	1 7/16	1/16	1.301	.011	.070	.003	.0166	33.05	0.28	1.78	0.08	
-028	1 3/8	1 1/2	1/16	1.364	.013	.070	.003	.0173	34.65	0.33	1.78	0.08	
-029	1 1/2	1 5/8	1/16	1.489	.013	.070	.003	.0188	37.82	0.33	1.78	0.08	
-030	1 5/8	1 3/4	1/16	1.614	.013	.070	.003	.0204	41.00	0.33	1.78	0.08	
-031	1 3/4	1 7/8	1/16	1.739	.015	.070	.003	.0219	44.17	0.38	1.78	0.08	
-032	1 7/8	2	1/16	1.864	.015	.070	.003	.0234	47.35	0.38	1.78	0.08	
-033	2	2 1/8	1/16	1.989	.018	.070	.003	.0249	50.52	0.46	1.78	0.08	
-034	2 1/8	2 1/4	1/16	2.114	.018	.070	.003	.0264	53.70	0.46	1.78	0.08	
-035	2 1/4	2 3/8	1/16	2.239	.018	.070	.003	.0279	56.87	0.46	1.78	0.08	
-036	2 3/8	2 1/2	1/16	2.364	.018	.070	.003	.0294	60.05	0.46	1.78	0.08	
-037	2 1/2	2 5/8	1/16	2.489	.018	.070	.003	.0309	63.22	0.46	1.78	0.08	
-038	2 5/8	2 3/4	1/16	2.614	.020	.070	.003	.0324	66.40	0.51	1.78	0.08	
-039	2 3/4	2 7/8	1/16	2.739	.020	.070	.003	.0340	69.57	0.51	1.78	0.08	
-040	2 7/8	3	1/16	2.864	.020	.070	.003	.0355	72.75	0.51	1.78	0.08	

AS568 O-Ring Sizes

1	2			3				4	5				
Size Only	Nominal Size			Standard O-Ring Size (Units are in inches)					Metric O-Ring Size (Units are in Millimeters)				
	(Inches)			Actual (b) Per AS 568A					Actual (b) Per AS 568A				
AS 568A Uniform Dash No.	(Ref. Only)				Tol.	(Ref. Only)			Basic Volume		Tol.	(Ref. Only)	
	I.D.	O.D.	W.	ID	±	W	±	Cu. In.	I.D.	±	W	±	
-041	3	3 1/8	1/16	2.989	.024	.070	.003	.0370	75.92	0.61	1.78	0.08	
-042	3 1/4	3 3/8	1/16	3.239	.024	.070	.003	.0400	82.27	0.61	1.78	0.08	
-043	3 1/2	3 5/8	1/16	3.489	.024	.070	.003	.0430	88.62	0.61	1.78	0.08	
-044	3 3/4	3 7/8	1/16	3.739	.027	.070	.003	.0460	94.97	0.69	1.78	0.08	
-045	4	4 1/8	1/16	3.989	.027	.070	.003	.0491	101.32	0.69	1.78	0.08	
-046	4 1/4	4 3/8	1/16	4.239	.030	.070	.003	.0521	107.67	0.76	1.78	0.08	
-047	4 1/2	4 5/8	1/16	4.489	.030	.070	.003	.0551	114.02	0.76	1.78	0.08	
-048	4 3/4	4 7/8	1/16	4.739	.030	.070	.003	.0581	120.37	0.76	1.78	0.08	
-049	5	5 1/8	1/16	4.989	.037	.070	.003	.0612	126.72	0.94	1.78	0.08	
-050	5 1/4	5 3/8	1/16	5.239	.037	.070	.003	.0642	133.07	0.94	1.78	0.08	
-102	1/16	1/4	3/32	.049	.005	.103	.003	.0040	1.24	0.13	2.62	0.08	
-103	3/32	9/32	3/32	.081	.005	.103	.003	.0048	2.06	0.13	2.62	0.08	
-104	1/8	5/16	3/32	.112	.005	.103	.003	.0056	2.84	0.13	2.62	0.08	
-105	5/32	11/32	3/32	.143	.005	.103	.003	.0064	3.63	0.13	2.62	0.08	
-106	3/16	3/8	3/32	.174	.005	.103	.003	.0072	4.42	0.13	2.62	0.08	
-107	7/32	13/32	3/32	.206	.005	.103	.003	.0081	5.23	0.13	2.62	0.08	
-108	1/4	7/16	3/32	.237	.005	.103	.003	.0089	6.02	0.13	2.62	0.08	
-109	5/16	1/2	3/32	.299	.005	.103	.003	.0105	7.59	0.13	2.62	0.08	
-110	3/8	9/16	3/32	.362	.005	.103	.003	.0122	9.19	0.13	2.62	0.08	
-111	7/16	5/8	3/32	.424	.005	.103	.003	.0138	10.77	0.13	2.62	0.08	
-112	1/2	11/16	3/32	.487	.005	.103	.003	.0154	12.37	0.13	2.62	0.08	
-113	9/16	3/4	3/32	.549	.007	.103	.003	.0171	13.94	0.18	2.62	0.08	
-114	5/8	13/16	3/32	.612	.009	.103	.003	.0187	15.54	0.23	2.62	0.08	
-115	11/16	7/8	3/32	.674	.009	.103	.003	.0203	17.12	0.23	2.62	0.08	
-116	3/4	15/16	3/32	.737	.009	.103	.003	.0220	18.72	0.23	2.62	0.08	
-117	13/16	1	3/32	.799	.010	.103	.003	.0236	20.30	0.25	2.62	0.08	
-118	7/8	1 1/6	3/32	.862	.010	.103	.003	.0253	21.89	0.25	2.62	0.08	
-119	15/16	1 1/8	3/32	.924	.010	.103	.003	.0269	23.47	0.25	2.62	0.08	
-120	1	1 3/16	3/32	.987	.010	.103	.003	.0285	25.07	0.25	2.62	0.08	
-121	1 1/16	1 1/4	3/32	1.049	.010	.103	.003	.0302	26.64	0.25	2.62	0.08	
-122	1 1/8	1 5/16	3/32	1.112	.010	.103	.003	.0318	28.24	0.25	2.62	0.08	
-123	1 3/16	1 3/8	3/32	1.174	.012	.103	.003	.0334	29.82	0.30	2.62	0.08	
-124	1 1/4	1 7/16	3/32	1.237	.012	.103	.003	.0351	31.42	0.30	2.62	0.08	
-125	1 5/16	1 1/2	3/32	1.299	.012	.103	.003	.0367	32.99	0.30	2.62	0.08	
-126	1 3/8	1 9/16	3/32	1.362	.012	.103	.003	.0383	34.59	0.30	2.62	0.08	
-127	1 7/16	1 5/8	3/32	1.424	.012	.103	.003	.0400	36.17	0.30	2.62	0.08	
-128	1 1/2	1 11/16	3/32	1.487	.012	.103	.003	.0416	37.77	0.30	2.62	0.08	
-129	1 9/16	1 3/4	3/32	1.549	.015	.103	.003	.0432	39.34	0.38	2.62	0.08	
-130	1 5/8	1 13/16	3/32	1.612	.015	.103	.003	.0449	40.94	0.38	2.62	0.08	
-131	1 11/16	1 7/8	3/32	1.674	.015	.103	.003	.0465	42.52	0.38	2.62	0.08	

AS568 O-Ring Sizes

1	2			3				4	5				
Size Only	Nominal Size			Standard O-Ring Size (Units are in inches)					Metric O-Ring Size (Units are in Millimeters)				
	(Inches)			Actual (b) Per AS 568A					Actual (b) Per AS 568A				
AS 568A Uniform Dash No.	(Ref. Only)				Tol.	(Ref. Only)			Basic Volume		Tol.		
	I.D.	O.D.	W.	ID	±	W	±	Cu. In.	I.D.	±	W	±	
-132	1 3/4	1 15/16	3/32	1.737	.015	.103	.003	.0482	44.12	0.38	2.62	0.08	
-133	1 13/16	2	3/32	1.799	.015	.103	.003	.0498	45.69	0.38	2.62	0.08	
-134	1 7/8	2 1/16	3/32	1.862	.015	.103	.003	.0514	47.29	0.38	2.62	0.08	
-135	1 15/16	2 1/8	3/32	1.925	.017	.103	.003	.0531	48.90	0.43	2.62	0.08	
-136	2	2 3/16	3/32	1.987	.017	.103	.003	.0547	50.47	0.43	2.62	0.08	
-137	2 1/16	2 1/4	3/32	2.050	.017	.103	.003	.0564	52.07	0.43	2.62	0.08	
-138	2 1/8	2 5/16	3/32	2.112	.017	.103	.003	.0580	53.64	0.43	2.62	0.08	
-139	2 3/16	2 3/8	3/32	2.175	.017	.103	.003	.0596	55.25	0.43	2.62	0.08	
-140	2 1/4	2 7/16	3/32	2.237	.017	.103	.003	.0612	56.82	0.43	2.62	0.08	
-141	2 5/16	2 1/2	3/32	2.300	.020	.103	.003	.0629	58.42	0.51	2.62	0.08	
-142	2 3/8	2 9/16	3/32	2.362	.020	.103	.003	.0645	59.99	0.51	2.62	0.08	
-143	2 7/16	2 5/8	3/32	2.425	.020	.103	.003	.0662	61.60	0.51	2.62	0.08	
-144	2 1/2	2 11/16	3/32	2.487	.020	.103	.003	.0678	63.17	0.51	2.62	0.08	
-145	2 9/16	2 3/4	3/32	2.550	.020	.103	.003	.0694	64.77	0.51	2.62	0.08	
-146	2 5/8	2 13/16	3/32	2.612	.020	.103	.003	.0711	66.34	0.51	2.62	0.08	
-147	2 11/16	2 7/8	3/32	2.675	.022	.103	.003	.0727	67.95	0.56	2.62	0.08	
-148	2 3/4	2 15/16	3/32	2.737	.022	.103	.003	.0743	69.52	0.56	2.62	0.08	
-149	2 13/16	3	3/32	2.800	.022	.103	.003	.0760	71.12	0.56	2.62	0.08	
-150	2 7/8	3 1/16	3/32	2.862	.022	.103	.003	.0776	72.69	0.56	2.62	0.08	
-151	3	3 3/16	3/32	2.987	.024	.103	.003	.0809	75.87	0.61	2.62	0.08	
-152	3 1/4	3 7/16	3/32	3.237	.024	.103	.003	.0874	82.22	0.61	2.62	0.08	
-153	3 1/2	3 11/16	3/32	3.487	.024	.103	.003	.0940	88.57	0.61	2.62	0.08	
-154	3 3/4	3 15/16	3/32	3.737	.028	.103	.003	.1005	94.92	0.71	2.62	0.08	
-155	4	4 3/16	3/32	3.987	.028	.103	.003	.1071	101.27	0.71	2.62	0.08	
-156	4 1/4	4 7/16	3/32	4.237	.030	.103	.003	.1136	107.62	0.76	2.62	0.08	
-157	4 1/2	4 11/16	3/32	4.487	.030	.103	.003	.1202	113.97	0.76	2.62	0.08	
-158	4 3/4	4 15/16	3/32	4.737	.030	.103	.003	.1267	120.32	0.76	2.62	0.08	
-159	5	5 3/16	3/32	4.987	.035	.103	.003	.1332	126.67	0.89	2.62	0.08	
-160	5 1/4	5 7/16	3/32	5.237	.035	.103	.003	.1398	133.02	0.89	2.62	0.08	
-161	5 1/2	5 11/16	3/32	5.487	.035	.103	.003	.1463	139.37	0.89	2.62	0.08	
-162	5 3/4	5 15/16	3/32	5.737	.035	.103	.003	.1529	145.72	0.89	2.62	0.08	
-163	6	6 3/16	3/32	5.987	.035	.103	.003	.1594	152.07	0.89	2.62	0.08	
-164	6 1/4	6 7/16	3/32	6.237	.040	.103	.003	.1660	158.42	1.02	2.62	0.08	
-165	6 1/2	6 11/16	3/32	6.487	.040	.103	.003	.1725	164.77	1.02	2.62	0.08	
-166	6 3/4	6 15/16	3/32	6.737	.040	.103	.003	.1790	171.12	1.02	2.62	0.08	
-167	7	7 3/16	3/32	6.987	.040	.103	.003	.1856	177.47	1.02	2.62	0.08	
-168	7 1/4	7 7/16	3/32	7.237	.045	.103	.003	.1921	183.82	1.14	2.62	0.08	
-169	7 1/2	7 11/16	3/32	7.487	.045	.103	.003	.1987	190.17	1.14	2.62	0.08	
-170	7 3/4	7 15/16	3/32	7.737	.045	.103	.003	.2052	196.52	1.14	2.62	0.08	
-171	8	8 3/16	3/32	7.987	.045	.103	.003	.2118	202.87	1.14	2.62	0.08	

AS568 O-Ring Sizes

1	2			3				4	5				
Size Only	Nominal Size			Standard O-Ring Size (Units are in inches)					Metric O-Ring Size (Units are in Millimeters)				
	(Inches)			Actual (b) Per AS 568A					Actual (b) Per AS 568A				
AS 568A Uniform Dash No.	(Ref. Only)				Tol.	(Ref. Only)			Basic Volume		Tol.		
	I.D.	O.D.	W.	ID	±	W	±	Cu. In.	I.D.	±	W	±	
-172	8 1/4	8 7/16	3/32	8.237	.050	.103	.003	.2183	209.22	1.27	2.62	0.08	
-173	8 1/2	8 11/16	3/32	8.487	.050	.103	.003	.2249	215.57	1.27	2.62	0.08	
-174	8 3/4	8 15/16	3/32	8.737	.050	.103	.003	.2314	221.92	1.27	2.62	0.08	
-175	9	9 3/16	3/32	8.987	.050	.103	.003	.2379	228.27	1.27	2.62	0.08	
-176	9 1/4	9 7/16	3/32	9.237	.055	.103	.003	.2445	234.62	1.40	2.62	0.08	
-177	9 1/2	9 11/16	3/32	9.487	.055	.103	.003	.2510	240.97	1.40	2.62	0.08	
-178	9 3/4	9 15/16	3/32	9.737	.055	.103	.003	.2576	247.32	1.40	2.62	0.08	
-201	3/16	7/16	1/8	.171	.005	.139	.004	.0148	4.34	0.13	3.53	0.10	
-202	1/4	1/2	1/8	.234	.005	.139	.004	.0178	5.94	0.13	3.53	0.10	
-203	5/16	9/16	1/8	.296	.005	.139	.004	.0207	7.52	0.13	3.53	0.10	
-204	3/8	5/8	1/8	.359	.005	.139	.004	.0237	9.12	0.13	3.53	0.10	
-205	7/16	11/16	1/8	.421	.005	.139	.004	.0267	10.69	0.13	3.53	0.10	
-206	1/2	3/4	1/8	.484	.005	.139	.004	.0297	12.29	0.13	3.53	0.10	
-207	9/16	13/16	1/8	.546	.007	.139	.004	.0327	13.87	0.18	3.53	0.10	
-208	5/8	7/8	1/8	.609	.009	.139	.004	.0357	15.47	0.23	3.53	0.10	
-209	11/16	15/16	1/8	.671	.010	.139	.004	.0386	17.04	0.23	3.53	0.10	
-210	3/4	1	1/8	.734	.010	.139	.004	.0416	18.64	0.25	3.53	0.10	
-211	13/16	1 1/16	1/8	.796	.010	.139	.004	.0446	20.22	0.25	3.53	0.10	
-212	7/8	1 1/8	1/8	.859	.010	.139	.004	.0476	21.82	0.25	3.53	0.10	
-213	15/16	1 3/16	1/8	.921	.010	.139	.004	.0505	23.39	0.25	3.53	0.10	
-214	1	1 1/4	1/8	.984	.010	.139	.004	.0535	24.99	0.25	3.53	0.10	
-215	1 1/16	1 5/16	1/8	1.046	.010	.139	.004	.0565	26.57	0.25	3.53	0.10	
-216	1 1/8	1 3/8	1/8	1.109	.012	.139	.004	.0595	28.17	0.30	3.53	0.10	
-217	1 3/16	1 7/16	1/8	1.171	.012	.139	.004	.0624	29.74	0.30	3.53	0.10	
-218	1 1/4	1 1/2	1/8	1.234	.012	.139	.004	.0654	31.34	0.30	3.53	0.10	
-219	1 5/16	1 9/16	1/8	1.296	.012	.139	.004	.0684	32.92	0.30	3.53	0.10	
-220	1 3/8	1 5/8	1/8	1.359	.012	.139	.004	.0714	34.52	0.30	3.53	0.10	
-221	1 7/16	1 11/16	1/8	1.421	.012	.139	.004	.0744	36.09	0.30	3.53	0.10	
-222	1 1/2	1 3/4	1/8	1.484	.015	.139	.004	.0774	37.69	0.38	3.53	0.10	
-223	1 5/8	1 7/8	1/8	1.609	.015	.139	.004	.0833	40.87	0.38	3.53	0.10	
-224	1 3/4	2	1/8	1.734	.015	.139	.004	.0893	44.04	0.38	3.53	0.10	
-225	1 7/8	2 1/8	1/8	1.859	.018	.139	.004	.0952	47.22	0.46	3.53	0.10	
-226	2	2 1/4	1/8	1.984	.018	.139	.004	.1012	50.39	0.46	3.53	0.10	
-227	2 1/8	2 3/8	1/8	2.109	.018	.139	.004	.1072	53.57	0.46	3.53	0.10	
-228	2 1/4	2 1/2	1/8	2.234	.020	.139	.004	.1131	56.74	0.51	3.53	0.10	
-229	2 3/8	2 5/8	1/8	2.359	.020	.139	.004	.1191	59.92	0.51	3.53	0.10	
-230	2 1/2	2 3/4	1/8	2.484	.020	.139	.004	.1250	63.09	0.51	3.53	0.10	
-231	2 5/8	2 7/8	1/8	2.609	.020	.139	.004	.1310	66.27	0.51	3.53	0.10	
-232	2 3/4	3	1/8	2.734	.024	.139	.004	.1370	69.44	0.61	3.53	0.10	
-233	2 7/8	3 1/8	1/8	2.859	.024	.139	.004	.1429	72.62	0.61	3.53	0.10	

AS568 O-Ring Sizes

1	2			3				4	5				
Size Only	Nominal Size			Standard O-Ring Size (Units are in inches)					Metric O-Ring Size (Units are in Millimeters)				
	(Inches)			Actual (b) Per AS 568A					Actual (b) Per AS 568A				
AS 568A Uniform Dash No.	(Ref. Only)				Tol.	(Ref. Only)			Basic Volume		Tol.		
	I.D.	O.D.	W.	ID	±	W	±	Cu. In.	I.D.	±	W	±	
-234	3	3 1/4	1/8	2.984	.024	.139	.004	.1489	75.79	0.61	3.53	0.10	
-235	3 1/8	3 3/8	1/8	3.109	.024	.139	.004	.1548	78.97	0.61	3.53	0.10	
-236	3 1/4	3 1/2	1/8	3.234	.024	.139	.004	.1608	82.14	0.61	3.53	0.10	
-237	3 3/8	3 5/8	1/8	3.359	.024	.139	.004	.1668	85.32	0.61	3.53	0.10	
-238	3 1/2	3 3/4	1/8	3.484	.024	.139	.004	.1727	88.49	0.61	3.53	0.10	
-239	3 5/8	3 7/8	1/8	3.609	.028	.139	.004	.1787	91.67	0.71	3.53	0.10	
-240	3 3/4	4	1/8	3.734	.028	.139	.004	.1846	94.84	0.71	3.53	0.10	
-241	3 7/8	4 1/8	1/8	3.859	.028	.139	.004	.1906	98.02	0.71	3.53	0.10	
-242	4	4 1/4	1/8	3.984	.028	.139	.004	.1966	101.19	0.71	3.53	0.10	
-243	4 1/8	4 3/8	1/8	4.109	.028	.139	.004	.2025	104.37	0.71	3.53	0.10	
-244	4 1/4	4 1/2	1/8	4.234	.030	.139	.004	.2085	107.54	0.76	3.53	0.10	
-245	4 3/8	4 5/8	1/8	4.359	.030	.139	.004	.2144	110.72	0.76	3.53	0.10	
-246	4 1/2	4 3/4	1/8	4.484	.030	.139	.004	.2204	113.89	0.76	3.53	0.10	
-247	4 5/8	4 7/8	1/8	4.609	.030	.139	.004	.2264	117.07	0.76	3.53	0.10	
-248	4 3/4	5	1/8	4.734	.030	.139	.004	.2323	120.24	0.76	3.53	0.10	
-249	4 7/8	5 1/8	1/8	4.859	.035	.139	.004	.2383	123.42	0.89	3.53	0.10	
-250	5	5 1/4	1/8	4.984	.035	.139	.004	.2442	126.59	0.89	3.53	0.10	
-251	5 1/8	5 3/8	1/8	5.109	.035	.139	.004	.2502	129.77	0.89	3.53	0.10	
-252	5 1/4	5 1/2	1/8	5.234	.035	.139	.004	.2561	132.94	0.89	3.53	0.10	
-253	5 3/8	5 5/8	1/8	5.359	.035	.139	.004	.2621	136.12	0.89	3.53	0.10	
-254	5 1/2	5 3/4	1/8	5.484	.035	.139	.004	.2681	139.29	0.89	3.53	0.10	
-255	5 5/8	5 7/8	1/8	5.609	.035	.139	.004	.2740	142.47	0.89	3.53	0.10	
-256	5 3/4	6	1/8	5.734	.035	.139	.004	.2800	145.64	0.89	3.53	0.10	
-257	5 7/8	6 1/8	1/8	5.859	.035	.139	.004	.2859	148.82	0.89	3.53	0.10	
-258	6	6 1/4	1/8	5.984	.035	.139	.004	.2919	151.99	0.89	3.53	0.10	
-259	6 1/4	6 1/2	1/8	6.234	.040	.139	.004	.3038	158.34	1.02	3.53	0.10	
-260	6 1/2	6 3/4	1/8	6.484	.040	.139	.004	.3157	164.69	1.02	3.53	0.10	
-261	6 3/4	7	1/8	6.734	.040	.139	.004	.3277	171.04	1.02	3.53	0.10	
-262	7	7 1/4	1/8	6.984	.040	.139	.004	.3396	177.39	1.02	3.53	0.10	
-263	7 1/4	7 1/2	1/8	7.234	.045	.139	.004	.3515	183.74	1.14	3.53	0.10	
-264	7 1/2	7 3/4	1/8	7.484	.045	.139	.004	.3634	190.09	1.14	3.53	0.10	
-265	7 3/4	8	1/8	7.734	.045	.139	.004	.3753	196.44	1.14	3.53	0.10	
-266	8	8 1/4	1/8	7.984	.045	.139	.004	.3872	202.79	1.14	3.53	0.10	
-267	8 1/4	8 1/2	1/8	8.234	.050	.139	.004	.3992	209.14	1.27	3.53	0.10	
-268	8 1/2	8 3/4	1/8	8.484	.050	.139	.004	.4111	215.49	1.27	3.53	0.10	
-269	8 3/4	9	1/8	8.734	.050	.139	.004	.4230	221.84	1.27	3.53	0.10	
-270	9	9 1/4	1/8	8.984	.050	.139	.004	.4349	228.19	1.27	3.53	0.10	
-271	9 1/4	9 1/2	1/8	9.234	.055	.139	.004	.4468	234.54	1.40	3.53	0.10	
-272	9 1/2	9 3/4	1/8	9.484	.055	.139	.004	.4588	240.89	1.40	3.53	0.10	
-273	9 3/4	10	1/8	9.734	.055	.139	.004	.4707	247.24	1.40	3.53	0.10	

AS568 O-Ring Sizes

1	2			3				4	5				
Size Only	Nominal Size			Standard O-Ring Size (Units are in inches)					Metric O-Ring Size (Units are in Millimeters)				
	(Inches)			Actual (b) Per AS 568A					Actual (b) Per AS 568A				
AS 568A Uniform Dash No.	(Ref. Only)				Tol.	(Ref. Only)			Basic Volume		Tol.		
	I.D.	O.D.	W.	ID	±	W	±	Cu. In.	I.D.	±	W	±	
-274	10	10 1/4	1/8	9.984	.055	.139	.004	.4826	253.59	1.40	3.53	0.10	
-275	10 1/2	10 3/4	1/8	10.484	.055	.139	.004	.5064	266.29	1.40	3.53	0.10	
-276	11	11 1/4	1/8	10.984	.065	.139	.004	.5303	278.99	1.65	3.53	0.10	
-277	11 1/2	11 3/4	1/8	11.484	.065	.139	.004	.5541	291.69	1.65	3.53	0.10	
-278	12	12 1/4	1/8	11.984	.065	.139	.004	.5779	304.39	1.65	3.53	0.10	
-279	13	13 1/4	1/8	12.984	.065	.139	.004	.6256	329.79	1.65	3.53	0.10	
-280	14	14 1/4	1/8	13.984	.065	.139	.004	.6733	355.19	1.65	3.53	0.10	
-281	15	15 1/4	1/8	14.984	.065	.139	.004	.7210	380.59	1.65	3.53	0.10	
-282	16	16 1/4	1/8	15.955	.075	.139	.004	.7672	405.26	1.91	3.53	0.10	
-283	17	17 1/4	1/8	16.955	.080	.139	.004	.8149	430.66	2.03	3.53	0.10	
-284	18	18 1/4	1/8	17.955	.085	.139	.004	.8626	456.06	2.16	3.53	0.10	
-309	7/16	13/16	3/16	.412	.005	.210	.005	.0677	10.46	0.13	5.33	0.13	
-310	1/2	7/8	3/16	.475	.005	.210	.005	.0745	12.07	0.13	5.33	0.13	
-311	9/16	15/16	3/16	.537	.007	.210	.005	.0813	13.64	0.18	5.33	0.13	
-312	5/8	1	3/16	.600	.009	.210	.005	.0881	15.24	0.23	5.53	0.13	
-313	11/16	1 1/16	3/16	.662	.009	.210	.005	.0949	16.81	0.23	5.33	0.13	
-314	3/4	1 1/8	3/16	.725	.010	.210	.005	.1017	18.42	0.25	5.33	0.13	
-315	13/16	1 3/16	3/16	.787	.010	.210	.005	.1085	19.99	0.25	5.33	0.13	
-316	7/8	1 1/4	3/16	.850	.010	.210	.005	.1153	21.59	0.25	5.33	0.13	
-317	15/16	1 5/16	3/16	.912	.010	.210	.005	.1221	23.16	0.25	5.33	0.13	
-318	1	1 3/8	3/16	.975	.010	.210	.005	.1289	24.77	0.25	5.53	0.13	
-319	1 1/16	1 7/16	3/16	1.037	.010	.210	.005	.1357	26.34	0.25	5.33	0.13	
-320	1 1/8	1 1/2	3/16	1.100	.012	.210	.005	.1425	27.94	0.30	5.33	0.13	
-321	1 3/16	1 9/16	3/16	1.162	.012	.210	.005	.1493	29.51	0.30	5.33	0.13	
-322	1 1/4	1 5/8	3/16	1.225	.012	.210	.005	.1561	31.12	0.30	5.33	0.13	
-323	1 5/16	1 11/16	3/16	1.287	.012	.210	.005	.1629	32.69	0.30	5.53	0.13	
-324	1 3/8	1 3/4	3/16	1.350	.012	.210	.005	.1697	34.29	0.30	5.33	0.13	
-325	1 1/2	1 7/8	3/16	1.475	.015	.210	.005	.1833	37.47	0.38	5.33	0.13	
-326	1 5/8	2	3/16	1.600	.015	.210	.005	.1970	40.64	0.38	5.33	0.13	
-327	1 3/4	2 1/8	3/16	1.725	.015	.210	.005	.2106	43.82	0.38	5.33	0.13	
-328	1 7/8	2 1/4	3/16	1.850	.015	.210	.005	.2242	46.99	0.38	5.53	0.13	
-329	2	2 3/8	3/16	1.975	.018	.210	.005	.2378	50.17	0.46	5.33	0.13	
-330	2 1/8	2 1/2	3/16	2.100	.018	.210	.005	.2514	53.34	0.46	5.33	0.13	
-331	2 1/4	2 5/8	3/16	2.225	.018	.210	.005	.2650	56.52	0.46	5.33	0.13	
-332	2 3/8	2 3/4	3/16	2.350	.018	.210	.005	.2786	59.69	0.46	5.33	0.13	
-333	2 1/2	2 7/8	3/16	2.475	.020	.210	.005	.2922	62.87	0.51	5.53	0.13	
-334	2 5/8	3	3/16	2.600	.020	.210	.005	.3058	66.04	0.51	5.33	0.13	
-335	2 3/4	3 1/8	3/16	2.725	.020	.210	.005	.3194	69.22	0.51	5.33	0.13	
-336	2 7/8	3 1/4	3/16	2.850	.020	.210	.005	.3330	72.39	0.51	5.33	0.13	
-337	3	3 3/8	3/16	2.975	.024	.210	.005	.3466	75.57	0.61	5.33	0.13	

AS568 O-Ring Sizes

1	2			3				4	5				
Size Only	Nominal Size			Standard O-Ring Size (Units are in inches)				Basic Volume	Metric O-Ring Size Units are in Millimeters				
	(Inches)			Actual (b) Per AS 568A					Actual (b) Per AS 568A				
AS 568A Uniform Dash No.	(Ref. Only)				Tol.	(Ref. Only)			Cu. In.	Tol.			
	I.D.	O.D.	W.	ID	±	W	±	I.D.		±	W	±	
-338	3 1/8	3 1/2	3/16	3.100	.024	.210	.005	.3602	78.74	0.61	5.53	0.13	
-339	3 1/4	3 5/8	3/16	3.225	.024	.210	.005	.3738	81.92	0.61	5.33	0.13	
-340	3 3/8	3 3/4	3/16	3.350	.024	.210	.005	.3874	85.09	0.61	5.33	0.13	
-341	3 1/2	3 7/8	3/16	3.475	.024	.210	.005	.4010	88.27	0.61	5.33	0.13	
-342	3 5/8	4	3/16	3.600	.028	.210	.005	.4146	91.44	0.71	5.33	0.13	
-343	3 3/4	4 1/8	3/16	3.725	.028	.210	.005	.4282	94.62	0.71	5.53	0.13	
-344	3 7/8	4 1/4	3/16	3.850	.028	.210	.005	.4418	97.79	0.71	5.33	0.13	
-345	4	4 3/8	3/16	3.975	.028	.210	.005	.4554	100.97	0.71	5.33	0.13	
-346	4 1/8	4 1/2	3/16	4.100	.028	.210	.005	.4690	104.14	0.71	5.33	0.13	
-347	4 1/4	4 5/8	3/16	4.225	.030	.210	.005	.4826	107.32	0.76	5.33	0.13	
-348	4 3/8	4 3/4	3/16	4.350	.030	.210	.005	.4962	110.49	0.76	5.53	0.13	
-349	4 1/2	4 7/8	3/16	4.475	.030	.210	.005	.5098	113.67	0.76	5.33	0.13	
-350	4 5/8	5	3/16	4.600	.030	.210	.005	.5234	116.84	0.76	5.33	0.13	
-351	4 3/4	5 1/8	3/16	4.725	.030	.210	.005	.5370	120.02	0.76	5.33	0.13	
-352	4 7/8	5 1/4	3/16	4.850	.030	.210	.005	.5506	123.19	0.76	5.33	0.13	
-353	5	5 3/8	3/16	4.975	.037	.210	.005	.5642	126.37	0.94	5.33	0.13	
-354	5 1/8	5 1/2	3/16	5.100	.037	.210	.005	.5778	129.54	0.94	5.53	0.13	
-355	5 1/4	5 5/8	3/16	5.225	.037	.210	.005	.5914	132.72	0.94	5.33	0.13	
-356	5 3/8	5 3/4	3/16	5.350	.037	.210	.005	.6050	135.89	0.94	5.33	0.13	
-357	5 1/2	5 7/8	3/16	5.475	.037	.210	.005	.6186	139.07	0.94	5.33	0.13	
-358	5 5/8	6	3/16	5.600	.037	.210	.005	.6322	142.24	0.94	5.33	0.13	
-359	5 3/4	6 1/8	3/16	5.725	.037	.210	.005	.6458	145.42	0.94	5.53	0.13	
-360	5 7/8	6 1/4	3/16	5.850	.037	.210	.005	.6594	148.59	0.94	5.33	0.13	
-361	6	6 3/8	3/16	5.975	.037	.210	.005	.6730	151.77	0.94	5.33	0.13	
-362	6 1/4	6 5/8	3/16	6.225	.040	.210	.005	.7002	158.12	1.02	5.33	0.13	
-363	6 1/2	6 7/8	3/16	6.475	.040	.210	.005	.7274	164.47	1.02	5.33	0.13	
-364	6 3/4	7 1/8	3/16	6.725	.040	.210	.005	.7546	170.82	1.02	5.53	0.13	
-365	7	7 3/8	3/16	6.975	.040	.210	.005	.7818	177.17	1.02	5.33	0.13	
-366	7 1/4	7 5/8	3/16	7.225	.045	.210	.005	.8090	183.52	1.14	5.33	0.13	
-367	7 1/2	7 7/8	3/16	7.475	.045	.210	.005	.8362	189.87	1.14	5.33	0.13	
-368	7 3/4	8 1/8	3/16	7.725	.045	.210	.005	.8634	196.22	1.14	5.33	0.13	
-369	8	8 3/8	3/16	7.975	.045	.210	.005	.8906	202.57	1.14	5.53	0.13	
-370	8 1/4	8 5/8	3/16	8.225	.050	.210	.005	.9178	208.92	1.27	5.33	0.13	
-371	8 1/2	8 7/8	3/16	8.475	.050	.210	.005	.9450	215.27	1.27	5.33	0.13	
-372	8 3/4	9 1/8	3/16	8.725	.050	.210	.005	.9722	221.62	1.27	5.33	0.13	
-373	9	9 3/8	3/16	8.975	.050	.210	.005	.9994	227.97	1.27	5.33	0.13	
-374	9 1/4	9 5/8	3/16	9.225	.055	.210	.005	1.0266	234.32	1.40	5.53	0.13	
-375	9 1/2	9 7/8	3/16	9.475	.055	.210	.005	1.0538	240.67	1.40	5.33	0.13	
-376	9 3/4	10 1/8	3/16	9.725	.055	.210	.005	1.0810	247.02	1.40	5.33	0.13	
-377	10	10 3/8	3/16	9.975	.055	.210	.005	1.1083	253.37	1.40	5.33	0.13	

AS568 O-Ring Sizes

1	2			3				4	5				
Size Only	Nominal Size			Standard O-Ring Size (Units are in inches)				Basic Volume	Metric O-Ring Size Units are in Millimeters				
	(Inches)			Actual (b) Per AS 568A					Actual (b) Per AS 568A				
AS 568A Uniform Dash No.	(Ref. Only)			ID	Tol.	(Ref. Only)			Cu. In.	I.D.	Tol.	W	±
	I.D.	O.D.	W.		±	W	±	±					
-378	10 1/2	10 7/8	3/16	10.475	.060	.210	.005	1.1627	266.07	1.52	5.33	0.13	
-379	11	11 3/8	3/16	10.975	.060	.210	.005	1.2171	278.77	1.52	5.53	0.13	
-380	11 1/2	11 7/8	3/16	11.475	.065	.210	.005	1.2715	291.47	1.65	5.33	0.13	
-381	12	12 3/8	3/16	11.975	.065	.210	.005	1.3259	304.17	1.65	5.33	0.13	
-382	13	13 3/8	3/16	12.975	.065	.210	.005	1.4347	329.57	1.65	5.33	0.13	
-383	14	14 3/8	3/16	13.975	.070	.210	.005	1.5435	354.97	1.78	5.33	0.13	
-384	15	15 3/8	3/16	14.975	.070	.210	.005	1.6523	380.37	1.78	5.53	0.13	
-385	16	16 3/8	3/16	15.955	.075	.210	.005	1.7590	405.26	1.91	5.33	0.13	
-386	17	17 3/8	3/16	16.955	.080	.210	.005	1.8678	430.66	2.03	5.33	0.13	
-387	18	18 3/8	3/16	17.955	.085	.210	.005	1.9766	456.06	2.16	5.33	0.13	
-388	19	19 3/8	3/16	18.955	.090	.210	.005	2.0854	481.41	2.29	5.33	0.13	
-389	20	20 3/8	3/16	19.955	.095	.210	.005	2.1942	506.81	2.41	5.53	0.13	
-390	21	21 3/8	3/16	20.955	.095	.210	.005	2.3030	532.21	2.41	5.33	0.13	
-391	22	22 3/8	3/16	21.955	.100	.210	.005	2.4118	557.61	2.54	5.33	0.13	
-392	23	23 3/8	3/16	22.940	.105	.210	.005	2.5190	582.68	2.67	5.33	0.13	
-393	24	24 3/8	3/16	23.940	.110	.210	.005	2.6278	608.08	2.79	5.33	0.13	
-394	25	25 3/8	3/16	24.940	.115	.210	.005	2.7366	633.48	2.92	5.33	0.13	
-395	26	26 3/8	3/16	25.940	.120	.210	.005	2.8454	658.88	3.05	5.33	0.13	
-425	4 1/2	5	1/4	4.475	.033	.275	.006	.8863	113.67	0.84	6.99	0.15	
-426	4 5/8	5 1/8	1/4	4.600	.033	.275	.006	.9097	116.84	0.84	6.99	0.15	
-427	4 3/4	5 1/4	1/4	4.725	.033	.275	.006	.9330	120.02	0.84	6.99	0.15	
-428	4 7/8	5 3/8	1/4	4.850	.033	.275	.006	.9563	123.19	0.84	6.99	0.15	
-429	5	5 1/2	1/4	4.975	.037	.275	.006	.9796	126.37	0.94	6.99	0.15	
-430	5 1/8	5 5/8	1/4	5.100	.037	.275	.006	1.0030	129.54	0.94	6.99	0.15	
-431	5 1/4	5 3/4	1/4	5.225	.037	.275	.006	1.0263	132.72	0.94	6.99	0.15	
-432	5 3/8	5 7/8	1/4	5.350	.037	.275	.006	1.0496	135.89	0.94	6.99	0.15	
-433	5 1/2	6	1/4	5.475	.037	.275	.006	1.0729	139.07	0.94	6.99	0.15	
-434	5 5/8	6 1/8	1/4	5.600	.037	.275	.006	1.0963	142.24	0.94	6.99	0.15	
-435	5 3/4	6 1/4	1/4	5.725	.037	.275	.006	1.1196	145.42	0.94	6.99	0.15	
-436	5 7/8	6 3/8	1/4	5.850	.037	.275	.006	1.1429	148.59	0.94	6.99	0.15	
-437	6	6 1/2	1/4	5.975	.037	.275	.006	1.1662	151.77	0.94	6.99	0.15	
-438	6 1/4	6 3/4	1/4	6.225	.040	.275	.006	1.2129	158.12	1.02	6.99	0.15	
-439	6 1/2	7	1/4	6.475	.040	.275	.006	1.2595	164.47	1.02	6.99	0.15	
-440	6 3/4	7 1/4	1/4	6.725	.040	.275	.006	1.3062	170.82	1.02	6.99	0.15	
-441	7	7 1/2	1/4	6.975	.040	.275	.006	1.3528	177.17	1.02	6.99	0.15	
-442	7 1/4	7 3/4	1/4	7.225	.045	.275	.006	1.3995	183.52	1.14	6.99	0.15	
-443	7 1/2	8	1/4	7.475	.045	.275	.006	1.4461	189.87	1.14	6.99	0.15	
-444	7 3/4	8 1/4	1/4	7.725	.045	.275	.006	1.4928	196.22	1.14	6.99	0.15	
-445	8	8 1/2	1/4	7.975	.045	.275	.006	1.5394	202.57	1.14	6.99	0.15	
-446	8 1/2	9	1/4	8.475	.055	.275	.006	1.6327	215.27	1.40	6.99	0.15	

AS568 O-Ring Sizes

1	2			3				4	5				
Size Only	Nominal Size			Standard O-Ring Size (Units are in inches)					Metric O-Ring Size Units are in Millimeters				
	(Inches)			Actual (b) Per AS 568A					Actual (b) Per AS 568A				
AS 568A Uniform Dash No.	(Ref. Only)				Tol.	(Ref. Only)			Basic Volume		Tol.		
	I.D.	O.D.	W.	ID	±	W	±	Cu. In.	I.D.	±	W	±	
-447	9	9 1/2	1/4	8.975	.055	.275	.006	1.7260	227.97	1.40	6.99	0.15	
-448	9 1/2	10	1/4	9.475	.055	.275	.006	1.8193	240.67	1.40	6.99	0.15	
-449	10	10 1/2	1/4	9.975	.055	.275	.006	1.9126	253.37	1.40	6.99	0.15	
-450	10 1/2	11	1/4	10.475	.060	.275	.006	2.0059	266.07	1.52	6.99	0.15	
-451	11	11 1/2	1/4	10.975	.060	.275	.006	2.0992	278.77	1.52	6.99	0.15	
-452	11 1/2	12	1/4	11.475	.060	.275	.006	2.1925	291.47	1.52	6.99	0.15	
-453	12	12 1/2	1/4	11.975	.060	.275	.006	2.2858	304.17	1.52	6.99	0.15	
-454	12 1/2	13	1/4	12.475	.060	.275	.006	2.3791	316.87	1.52	6.99	0.15	
-455	13	13 1/2	1/4	12.975	.060	.275	.006	2.4724	329.57	1.52	6.99	0.15	
-456	13 1/2	14	1/4	13.475	.070	.275	.006	2.5657	342.27	1.78	6.99	0.15	
-457	14	14 1/2	1/4	13.975	.070	.275	.006	2.6590	354.97	1.78	6.99	0.15	
-458	14 1/2	15	1/4	14.475	.070	.275	.006	2.7523	367.67	1.78	6.99	0.15	
-459	15	15 1/2	1/4	14.975	.070	.275	.006	2.8456	380.37	1.78	6.99	0.15	
-460	15 1/2	16	1/4	15.475	.070	.275	.006	2.9389	393.07	1.78	6.99	0.15	
-461	16	16 1/2	1/4	15.955	.075	.275	.006	3.0285	405.26	1.91	6.99	0.15	
-462	16 1/2	17	1/4	16.455	.075	.275	.006	3.1218	417.96	1.91	6.99	0.15	
-463	17	17 1/2	1/4	16.955	.080	.275	.006	3.2151	430.66	2.03	6.99	0.15	
-464	17 1/2	18	1/4	17.455	.085	.275	.006	3.3084	443.36	2.16	6.99	0.15	
-465	18	18 1/2	1/4	17.955	.085	.275	.006	3.4017	456.06	2.16	6.99	0.15	
-466	18 1/2	19	1/4	18.455	.085	.275	.006	3.4950	468.76	2.16	6.99	0.15	
-467	19	19 1/2	1/4	18.955	.090	.275	.006	3.5883	481.46	2.29	6.99	0.15	
-468	19 1/2	20	1/4	19.455	.090	.275	.006	3.6816	494.16	2.29	6.99	0.15	
-469	20	20 1/2	1/4	19.955	.095	.275	.006	3.7749	506.86	2.41	6.99	0.15	
-470	21	21 1/2	1/4	20.955	.095	.275	.006	3.9615	532.26	2.41	6.99	0.15	
-471	22	22 1/2	1/4	21.955	.100	.275	.006	4.1481	557.66	2.54	6.99	0.15	
-472	23	23 1/2	1/4	22.940	.105	.275	.006	4.3319	582.68	2.67	6.99	0.15	
-473	24	24 1/2	1/4	23.940	.110	.275	.006	4.5185	608.08	2.79	6.99	0.15	
-474	25	25 1/2	1/4	24.940	.115	.275	.006	4.7051	633.48	2.92	6.99	0.15	
-475	26	26 1/2	1/4	25.940	.120	.275	.006	4.8917	658.88	3.05	6.99	0.15	



AS568 O-Ring Sizes

These O-Rings are intended for use with internal straight thread fluid connection bosses and tube fittings. Ref. AND10049, AND10050, MS33656, MS33657, SAE straight thread O-Ring boss and mating swivel and adjustable style fittings.

AS568A Dash No.	Tube O.D. (Ref.)	O-ring Size - Actual (b) per AS568A (Units are in inches)				Cross Section Area In ²	Metric O-ring Size per AS568A (b) (Units are in millimeters)			
		I.D.	Tol. ±	W	±		I.D.	Tol. ±	W	±
-901	3/32	.185	.005	.056	.003	.00246	4.70	0.13	1.42	0.08
-902	1/8	.239	.005	.064	.003	.00322	6.07	0.13	1.63	0.08
-903	3/16	.301	.005	.064	.003	.00322	7.65	0.13	1.63	0.08
-904	1/4	.351	.005	.072	.003	.00407	8.92	0.13	1.83	0.08
-905	5/16	.414	.005	.072	.003	.00407	10.52	0.13	1.83	0.08
-906	3/8	.468	.005	.078	.003	.00478	11.89	0.13	1.98	0.08
-907	7/16	.530	.007	.082	.003	.00528	13.46	0.18	2.08	0.08
-908	1/2	.644	.009	.087	.003	.00594	16.36	0.23	2.21	0.08
-909	9/16	.706	.009	.097	.003	.00739	17.93	0.23	2.46	0.08
-910	5/8	.755	.009	.097	.003	.00739	19.18	0.23	2.46	0.08
-911	11/16	.863	.009	.116	.004	.01057	21.92	0.23	2.95	0.10
-912	3/4	.924	.009	.116	.004	.01057	23.47	0.23	2.95	0.10
-913	13/16	.986	.010	.116	.004	.01057	25.04	0.26	2.95	0.10
-914	7/8	1.047	.010	.116	.004	.01057	26.59	0.26	2.95	0.10
-916	1	1.171	.010	.116	.004	.01057	29.74	0.26	2.95	0.10
-918	1 1/8	1.355	.012	.116	.004	.01057	34.42	0.30	2.95	0.10
-920	1 1/4	1.475	.014	.118	.004	.01094	37.47	0.36	3.00	0.10
-924	1 1/2	1.720	.014	.118	.004	.01094	43.69	0.36	3.00	0.10
-928	1 3/4	2.090	.018	.118	.004	.01094	53.09	0.46	3.00	0.10
-932	2	2.337	.018	.118	.004	.01094	59.36	0.46	3.00	0.10

- (a) The rubber compound must be added when ordering by these numbers.
- (b) Material with unusual shrinkage during molding will give slightly different dimensions.

JIS B2404 Sizes

JIS Size	ID		CSD		ID		CSD	JIS Size	ID		CSD		ID		CSD
	in	±	in	±	mm	±	mm		in	±	in	±	mm	±	mm
S-3	.098	.006	.059	.004	2.5	.15	1.5	S-135	5.295	.024	.079	.004	134.5	.60	2.0
S-4	.138	.006	.059	.004	3.5	.15	1.5	S-140	5.492	.024	.079	.004	139.5	.60	2.0
S-5	.177	.006	.059	.004	4.5	.15	1.5	S-145	5.689	.024	.079	.004	144.5	.60	2.0
S-6	.217	.006	.059	.004	5.5	.15	1.5	S-150	5.886	.024	.079	.004	149.5	.60	2.0
S-7	.256	.006	.059	.004	6.5	.15	1.5	P-3	0.110	.005	.075	.003	2.8	.12	1.9
S-8	.295	.006	.059	.004	7.5	.15	1.5	P-4	0.150	.005	.075	.003	3.8	.12	1.9
S-9	.335	.006	.059	.004	8.5	.15	1.5	P-5	0.189	.005	.075	.003	4.8	.12	1.9
S-10	.374	.006	.059	.004	9.5	.15	1.5	P-6	0.228	.005	.075	.003	5.8	.12	1.9
S-11.2	.421	.006	.059	.004	10.7	.15	1.5	P-7	0.268	.005	.075	.003	6.8	.12	1.9
S-12	.453	.006	.059	.004	11.5	.15	1.5	P-8	0.307	.005	.075	.003	7.8	.12	1.9
S-12.5	.472	.006	.059	.004	12.0	.15	1.5	P-9	0.346	.005	.075	.003	8.8	.12	1.9
S-14	.531	.006	.059	.004	13.5	.15	1.5	P-10	0.386	.005	.075	.003	9.8	.12	1.9
S-15	.571	.006	.059	.004	14.5	.15	1.5	P-10A	0.386	.005	.094	.003	9.8	.12	2.4
S-16	.610	.006	.059	.004	15.5	.15	1.5	P-11	0.425	.005	.094	.003	10.8	.12	2.4
S-18	.689	.006	.059	.004	17.5	.15	1.5	P-11.2	0.433	.005	.094	.003	11.0	.12	2.4
S-20	.768	.006	.059	.004	19.5	.15	1.5	P-12	0.465	.005	.094	.003	11.8	.12	2.4
S-22	.846	.006	.059	.004	21.5	.15	1.5	P-12.5	0.484	.005	.094	.003	12.3	.12	2.4
S-22.4	.862	.006	.079	.004	21.9	.15	2.0	P-14	0.543	.005	.094	.003	13.8	.12	2.4
S-24	.925	.006	.079	.004	23.5	.15	2.0	P-15	0.583	.005	.094	.003	14.8	.12	2.4
S-25	.965	.006	.079	.004	24.5	.15	2.0	P-16	0.622	.005	.094	.003	15.8	.12	2.4
S-26	1.004	.006	.079	.004	25.5	.15	2.0	P-18	0.701	.005	.094	.003	17.8	.12	2.4
S-28	1.083	.006	.079	.004	27.5	.15	2.0	P-20	0.780	.006	.094	.003	19.8	.15	2.4
S-29	1.122	.006	.079	.004	28.5	.15	2.0	P-21	0.819	.006	.094	.003	20.8	.15	2.4
S-30	1.161	.006	.079	.004	29.5	.15	2.0	P-22	0.858	.006	.094	.003	21.8	.15	2.4
S-31.5	1.220	.006	.079	.004	31.0	.15	2.0	P-22A	0.854	.006	.138	.004	21.7	.15	3.5
S-32	1.240	.006	.079	.004	31.5	.15	2.0	P-22.4	0.870	.006	.138	.004	22.1	.15	3.5
S-34	1.319	.006	.079	.004	33.5	.15	2.0	P-24	0.933	.006	.138	.004	23.7	.15	3.5
S-35	1.358	.006	.079	.004	34.5	.15	2.0	P-25	0.972	.006	.138	.004	24.7	.15	3.5
S-35.5	1.378	.006	.079	.004	35.0	.15	2.0	P-25.5	0.992	.006	.138	.004	25.2	.15	3.5
S-36	1.398	.006	.079	.004	35.5	.15	2.0	P-26	1.012	.006	.138	.004	25.7	.15	3.5
S-38	1.476	.006	.079	.004	37.5	.15	2.0	P-28	1.091	.006	.138	.004	27.7	.15	3.5
S-39	1.516	.006	.079	.004	38.5	.15	2.0	P-29	1.130	.006	.138	.004	28.7	.15	3.5
S-40	1.555	.006	.079	.004	39.5	.25	2.0	P-29.5	1.150	.006	.138	.004	29.2	.15	3.5
S-42	1.634	.010	.079	.004	41.5	.25	2.0	P30	1.169	.006	.138	.004	29.7	.15	3.5
S-44	1.713	.010	.079	.004	43.5	.25	2.0	P-31	1.209	.006	.138	.004	30.7	.15	3.5
S-45	1.752	.010	.079	.004	44.5	.25	2.0	P-31.5	1.228	.006	.138	.004	31.2	.15	3.5
S-46	1.791	.010	.079	.004	45.5	.25	2.0	P-32	1.248	.006	.138	.004	31.7	.15	3.5
S-48	1.870	.010	.079	.004	47.5	.25	2.0	P-34	1.327	.006	.138	.004	33.7	.15	3.5
S-50	1.949	.010	.079	.004	49.5	.25	2.0	P-35	1.366	.006	.138	.004	34.7	.15	3.5
S-53	2.067	.010	.079	.004	52.5	.25	2.0	P-35.5	1.386	.006	.138	.004	35.2	.15	3.5
S-55	2.146	.010	.079	.004	54.5	.25	2.0	P-36	1.406	.006	.138	.004	35.7	.15	3.5
S-56	2.185	.010	.079	.004	55.5	.25	2.0	P-38	1.484	.006	.138	.004	37.7	.15	3.5
S-60	2.343	.010	.079	.004	59.5	.25	2.0	P-39	1.524	.006	.138	.004	38.7	.15	3.5
S-63	2.461	.010	.079	.004	62.5	.25	2.0	P-40	1.563	.006	.138	.004	39.7	.15	3.5
S-65	2.539	.010	.079	.004	64.5	.25	2.0	P-41	1.602	.010	.138	.004	40.7	.25	3.5
S-67	2.618	.010	.079	.004	66.5	.25	2.0	P-42	1.642	.010	.138	.004	41.7	.25	3.5
S-70	2.736	.010	.079	.004	69.5	.25	2.0	P-44	1.720	.010	.138	.004	43.7	.25	3.5
S-71	2.776	.016	.079	.004	70.5	.40	2.0	P-45	1.760	.010	.138	.004	44.7	.25	3.5
S-75	2.933	.016	.079	.004	74.5	.40	2.0	P-46	1.799	.010	.138	.004	45.7	.25	3.5
S-80	3.130	.016	.079	.004	79.5	.40	2.0	P-48	1.878	.010	.138	.004	47.7	.25	3.5
S-85	3.327	.016	.079	.004	84.5	.40	2.0	P-49	1.917	.010	.138	.004	48.7	.25	3.5
S-90	3.524	.016	.079	.004	89.5	.40	2.0	P-50	1.957	.010	.138	.004	49.7	.25	3.5
S-95	3.720	.016	.079	.004	94.5	.40	2.0	P-48A	1.874	.010	.224	.006	47.6	.25	5.7
S-100	3.917	.016	.079	.004	99.5	.40	2.0	P-50A	1.953	.010	.224	.006	49.6	.25	5.7
S-105	4.114	.016	.079	.004	104.5	.40	2.0	P-52	2.031	.010	.224	.006	51.6	.25	5.7
S-110	4.311	.016	.079	.004	109.5	.40	2.0	P-53	2.071	.010	.224	.006	52.6	.25	5.7
S-112	4.390	.016	.079	.004	111.5	.40	2.0	P-55	2.150	.010	.224	.006	54.6	.25	5.7
S-115	4.508	.016	.079	.004	114.5	.40	2.0	P-56	2.189	.010	.224	.006	55.6	.25	5.7
S-120	4.705	.016	.079	.004	119.5	.40	2.0	P-58	2.268	.010	.224	.006	57.6	.25	5.7
S-125	4.902	.016	.079	.004	124.5	.40	2.0	P-60	2.346	.010	.224	.006	59.6	.25	5.7
S-130	5.098	.024	.079	.004	129.5	.60	2.0	P-62	2.425	.010	.224	.006	61.6	.25	5.7
S-132	5.177	.024	.079	.004	131.5	.60	2.0	P-63	2.465	.010	.224	.006	62.6	.25	5.7

JIS B2404 Sizes

JIS Size	ID in	±	CSD in	±	ID mm	±	CSD mm	JIS Size	ID in	±	CSD in	±	ID mm	±	CSD mm
P-65	2.543	.010	.224	.006	64.6	.25	5.7	P-385	15.138	.039	.331	.006	384.5	1.0	8.4
P-67	2.622	.010	.224	.006	66.6	.25	5.7	P-400	15.728	.039	.331	.006	399.5	1.0	8.4
P-70	2.740	.010	.224	.006	69.6	.25	5.7	G-25	0.961	.006	.122	.004	24.4	.15	3.1
P-71	2.780	.016	.224	.006	70.6	.40	5.7	G-30	1.157	.006	.122	.004	29.4	.15	3.1
P-75	2.937	.016	.224	.006	74.6	.40	5.7	G-35	1.354	.006	.122	.004	34.4	.15	3.1
P-80	3.134	.016	.224	.006	79.6	.40	5.7	G-40	1.551	.006	.122	.004	39.4	.15	3.1
P-85	3.331	.016	.224	.006	84.6	.40	5.7	G-45	1.748	.010	.122	.004	44.4	.25	3.1
P-90	3.528	.016	.224	.006	89.6	.40	5.7	G-50	1.945	.010	.122	.004	49.4	.25	3.1
P-95	3.724	.016	.224	.006	94.6	.40	5.7	G-55	2.142	.010	.122	.004	54.4	.25	3.1
P-100	3.921	.016	.224	.006	99.6	.40	5.7	G-60	2.339	.010	.122	.004	59.4	.25	3.1
P-102	4.000	.016	.224	.006	101.6	.40	5.7	G-65	2.535	.010	.122	.004	64.4	.25	3.1
P-105	4.118	.016	.224	.006	104.6	.40	5.7	G-70	2.732	.010	.122	.004	69.4	.25	3.1
P-110	4.315	.016	.224	.006	109.6	.40	5.7	G-75	2.929	.016	.122	.004	74.4	.40	3.1
P-112	4.394	.016	.224	.006	111.6	.40	5.7	G-80	3.126	.016	.122	.004	79.4	.40	3.1
P-115	4.512	.016	.224	.006	114.6	.40	5.7	G-85	3.323	.016	.122	.004	84.4	.40	3.1
P-120	4.709	.016	.224	.006	119.6	.40	5.7	G-90	3.520	.016	.122	.004	89.4	.40	3.1
P-125	4.906	.016	.224	.006	124.6	.40	5.7	G-95	3.717	.016	.122	.004	94.4	.40	3.1
P-130	5.102	.024	.224	.006	129.6	.60	5.7	G-100	3.913	.016	.122	.004	99.4	.40	3.1
P-132	5.181	.024	.224	.006	131.6	.60	5.7	G-105	4.110	.016	.122	.004	104.4	.40	3.1
P-135	5.299	.024	.224	.006	134.6	.60	5.7	G-110	4.307	.016	.122	.004	109.4	.40	3.1
P-140	5.496	.024	.224	.006	139.6	.60	5.7	G-115	4.504	.016	.122	.004	114.4	.40	3.1
P-145	5.693	.024	.224	.006	144.6	.60	5.7	G-120	4.701	.016	.122	.004	119.4	.40	3.1
P-150	5.890	.024	.224	.006	149.6	.60	5.7	G-125	4.898	.016	.122	.004	124.4	.40	3.1
P-150A	5.886	.024	.331	.006	149.5	.60	8.4	G-130	5.094	.024	.122	.004	129.4	.60	3.1
P-155	6.083	.024	.331	.006	154.5	.60	8.4	G-135	5.291	.024	.122	.004	134.4	.60	3.1
P-160	6.280	.024	.331	.006	159.5	.60	8.4	G-140	5.488	.024	.122	.004	139.4	.60	3.1
P-165	6.476	.024	.331	.006	164.5	.60	8.4	G-145	5.685	.024	.122	.004	144.4	.60	3.1
P-170	6.673	.024	.331	.006	169.5	.60	8.4	G-150	5.878	.024	.224	.006	149.3	.60	5.7
P-175	6.870	.024	.331	.006	174.5	.60	8.4	G-155	6.075	.024	.224	.006	154.3	.60	5.7
P-180	7.067	.024	.331	.006	179.5	.60	8.4	G-160	6.272	.024	.224	.006	159.3	.60	5.7
P-185	7.264	.031	.331	.006	184.5	.80	8.4	G-165	6.469	.024	.224	.006	164.3	.60	5.7
P-190	7.461	.031	.331	.006	189.5	.80	8.4	G-170	6.665	.024	.224	.006	169.3	.60	5.7
P-195	7.657	.031	.331	.006	194.5	.80	8.4	G-175	6.862	.024	.224	.006	174.3	.60	5.7
P-200	7.854	.031	.331	.006	199.5	.80	8.4	G-180	7.059	.024	.224	.006	179.3	.60	5.7
P-205	8.051	.031	.331	.006	204.5	.80	8.4	G-185	7.256	.031	.224	.006	184.3	.80	5.7
P-209	8.209	.031	.331	.006	208.5	.80	8.4	G-190	7.453	.031	.224	.006	189.3	.80	5.7
P-210	8.248	.031	.331	.006	209.5	.80	8.4	G-195	7.650	.031	.224	.006	194.3	.80	5.7
P-215	8.445	.031	.331	.006	214.5	.80	8.4	G-200	7.846	.031	.224	.006	199.3	.80	5.7
P-220	8.642	.031	.331	.006	219.5	.80	8.4	G-210	8.240	.031	.224	.006	209.3	.80	5.7
P-225	8.839	.031	.331	.006	224.5	.80	8.4	G-220	8.634	.031	.224	.006	219.3	.80	5.7
P-230	9.035	.031	.331	.006	229.5	.80	8.4	G-230	9.028	.031	.224	.006	229.3	.80	5.7
P-235	9.232	.031	.331	.006	234.5	.80	8.4	G-240	9.421	.031	.224	.006	239.3	.80	5.7
P-240	9.429	.031	.331	.006	239.5	.80	8.4	G-250	9.815	.031	.224	.006	249.3	.80	5.7
P-245	9.626	.031	.331	.006	244.5	.80	8.4	G-255	10.012	.031	.224	.006	254.3	.80	5.7
P-250	9.823	.031	.331	.006	249.5	.80	8.4	G-260	10.209	.031	.224	.006	259.3	.80	5.7
P-255	10.020	.031	.331	.006	254.5	.80	8.4	G-270	10.602	.031	.224	.006	269.3	.80	5.7
P-260	10.217	.031	.331	.006	259.5	.80	8.4	G-280	10.996	.031	.224	.006	279.3	.80	5.7
P-265	10.413	.031	.331	.006	264.5	.80	8.4	G-290	11.390	.031	.224	.006	289.3	.80	5.7
P-270	10.610	.031	.331	.006	269.5	.80	8.4	G-300	11.783	.031	.224	.006	299.3	.80	5.7
P-275	10.807	.031	.331	.006	274.5	.80	8.4	V-15	0.571	.006	.157	.004	14.5	.15	4.0
P-280	11.004	.031	.331	.006	279.5	.80	8.4	V-24	0.925	.006	.157	.004	23.5	.15	4.0
P-285	11.201	.031	.331	.006	284.5	.80	8.4	V-34	1.319	.006	.157	.004	33.5	.15	4.0
P-290	11.398	.031	.331	.006	289.5	.80	8.4	V-40	1.555	.006	.157	.004	39.5	.15	4.0
P-295	11.594	.031	.331	.006	294.5	.80	8.4	V-55	2.146	.010	.157	.004	54.5	.25	4.0
P-300	11.791	.031	.331	.006	299.5	.80	8.4	V-70	2.717	.010	.157	.004	69.0	.25	4.0
P-315	12.382	.039	.331	.006	314.5	1.0	8.4	V-85	3.307	.016	.157	.004	84.0	.40	4.0
P-320	12.579	.039	.331	.006	319.5	1.0	8.4	V-100	3.898	.016	.157	.004	99.0	.40	4.0
P-335	13.169	.039	.331	.006	334.5	1.0	8.4	V-120	4.685	.016	.157	.004	119.0	.40	4.0
P-340	13.366	.039	.331	.006	339.5	1.0	8.4	V-150	5.846	.024	.157	.004	148.5	.60	4.0
P-355	13.957	.039	.331	.006	354.5	1.0	8.4	V-175	6.811	.024	.157	.004	173.0	.60	4.0
P-360	14.154	.039	.331	.006	359.5	1.0	8.4	V-225	8.760	.031	.236	.006	222.5	.80	6.0
P-375	14.744	.039	.331	.006	374.5	1.0	8.4	V-275	10.709	.031	.236	.006	272.0	.80	6.0



JIS B2404 Sizes

JIS	ID		CSD		ID		CSD	JIS	ID		CSD		ID		CS D
Size	in	±	in	±	mm	±	mm	Size	in	±	in	±	mm	±	mm
V-325	12.657	.039	.236	.006	321.5	1.00	6.0	V-690	26.890	.063	.394	.012	683.0	1.60	10.0
V-380	14.803	.039	.236	.006	376.0	1.00	6.0	V-740	28.839	.079	.394	.012	732.5	2.00	10.0
V-430	16.752	.047	.236	.006	425.5	1.20	6.0	V-790	30.787	.079	.394	.012	782.0	2.00	10.0
V-480	18.701	.047	.394	.012	475.0	1.20	10.0	V-845	32.933	.079	.394	.012	836.5	2.00	10.0
V-530	20.650	.063	.394	.012	524.5	1.60	10.0	V-950	37.028	.098	.394	.012	940.5	2.50	10.0
V-585	22.795	.063	.394	.012	579.0	1.60	10.0	V-1055	41.102	.118	.394	.012	1044.0	3.00	10.0
V-640	24.941	.063	.394	.012	633.5	1.60	10.0								

Fraction, Decimal, and Millimeter conversion

Millimeters (mm) divide by 25.4 = Inches (in) Inches (in) times 25.4 = Millimeters (mm)			1 Millimeter (mm) = .03937 Inches (in) .001 Inch (in) = .0254 Millimeter (mm)		
Fraction	Decimal (in)	mm	Fraction	Decimal (in)	mm
1/64	.0156	0.3968	33/64	.5156	13.0967
1/32	.0312	0.7937	17/32	.5312	13.4963
3/64	.0468	1.1906	35/64	.5468	13.8904
1/16	.0625	1.5874	9/16	.5625	14.2873
5/64	.0781	1.9843	37/64	.5781	14.6841
3/32	.0937	2.3812	19/32	.5937	15.0811
7/64	.1093	2.7780	39/64	.6093	15.4779
1/8	.1250	3.1749	5/8	.6250	15.8748
9/64	.1406	3.5718	41/64	.6406	16.2716
5/32	.1562	3.9687	21/32	.6562	16.6685
11/64	.1718	4.3655	43/64	.6718	17.0654
3/16	.1875	4.7624	11/16	.6875	17.4623
13/64	.2031	5.1593	45/64	.7031	17.8591
7/32	.2187	5.5562	23/32	.7187	18.2560
15/64	.2343	5.9530	47/64	.7343	18.6528
1/4	.2500	6.3499	3/4	.7500	19.0498
17/64	.2656	6.7467	49/64	.7656	19.4466
9/32	.2812	7.1436	25/32	.7812	19.8435
19/64	.2968	7.5405	51/64	.7968	20.2403
5/16	.3125	7.9374	13/16	.8125	20.6373
21/64	.3281	8.3342	53/64	.8281	21.0341
11/32	.3437	8.7311	27/32	.8437	21.4310
23/64	.3593	9.1280	55/64	.8593	21.8278
3/8	.3750	9.5249	7/8	.8750	22.2247
25/64	.3906	9.9217	57/64	.8906	22.6215
13/32	.4062	10.3186	29/32	.9062	23.0185
27/64	.4218	10.7154	59/64	.9218	23.4153
7/16	.4375	11.1124	15/16	.9375	23.8122
29/64	.4531	11.5092	61/64	.9531	24.2090
15/32	.4687	11.9061	31/32	.9687	24.6060
31/64	.4843	12.3029	63/64	.9843	25.0028
1/2	.5000	12.6998	1	1.000	25.3997

Chemical Compatibility Table

1 = recommended
 2 = marginal
 3 = unsatisfactory
 X = insufficient data

Compound	Temperature Range	Compound	Temperature Range
Fluoroelastomer (FKM)	-26°C to 205°C (-15°F to 400°F)	Nitrile (NBR)	-34°C to 121°C (-30°F to 250°F)
Fluorosilicone (FVMQ)	-73°C to 190°C (-100°F to 375°F)	Ethylene Propylene (EPDM)	-57°C to 149°C (-70°F to 300°F)
Perfluoroelastomer (FFKM)	-26°C to 316°C (-15°F to 600°F)	Silicone (VMQ)	-54°C to 232°C (-65°F to 450°F)

ALWAYS TEST UNDER ACTUAL SERVICE CONDITIONS.

Published Temperature ranges will apply to majority of media for which the material is recommended.

Fluid	Material						Fluid	Material					
	Perfluoroelastomer	Nitrile	Ethylene Propylene	Silicone	Fluoroelastomer	Fluorosilicone		Perfluoroelastomer	Nitrile	Ethylene Propylene	Silicone	Fluoroelastomer	Fluorosilicone
Abietic Acid	1	X	X	X	X	X	Air Below 200° F	1	2	1	1	1	1
Acetaldehyde	2	3	1	1	3	3	Air, 200 - 300° F	X	3	2	1	1	1
Acetamide	1	1	1	2	3	1	Air, 300 - 400° F	X	3	3	1	1	2
Acetanilide	1	3	1	2	3	1	Air, 400 - 500° F	X	3	3	2	3	3
Acetic Acid	X	2	1	1	3	3	Aliphatic Dicarboxylic Acid	X	2	3	X	1	2
Acetic Acid, 30%	1	2	1	1	2	2	Alkanesulfonic Acid	1	1	3	2	1	1
Acetic Acid, 5%	X	2	1	1	1	2	Alkazene	1	3	3	3	2	2
Acetic Acid, Glacial	1	2	1	1	2	2	Alkenes (Olefin Hydrocarbons)	1	2	3	X	1	2
Acetic Acid, Hot, High Pressure	X	3	3	3	3	3	Alkenes (Paraffin Hydrocarbons)	X	1	3	2	1	1
Acetic Anhydride	1	3	2	2	3	3	Alkyl (Alcohol, Arylsulfonates, & Arylsulfonics)	1	1	3	2	1	1
Acetophenetidine	1	2	3	X	1	2	Alkyl Amine	1	1	3	2	1	1
Acetotoluidide	1	2	3	X	1	2	Alkyl (Benzene, Chloride, & Sulfide)	1	2	3	X	1	2
Acetoacetic Acid	1	3	1	2	3	1	Alkyl Acetone	1	3	1	2	3	1
Acetone	1	3	1	2	3	3	Alkyl naphthalene Sulfonic Acid	1	1	3	2	1	1
Acetone Cyanohydrin	1	3	1	2	3	1	Allyl Chloride	1	2	3	X	1	X
Acetonitrile	1	3	1	X	1	X	Allylidene Diacetate	1	3	1	2	3	1
Acetophenone	1	3	1	3	3	3	Alpha Picoline	1	3	1	2	3	1
Acetyl Acetone	1	3	1	3	3	3	Aluminum Acetate	1	2	1	3	3	3
Acetyl Bromide	1	3	1	3	1	3	Aluminum Bromide	1	1	1	1	1	1
Acetyl Chloride	1	3	3	3	1	1	Aluminum (Chlorate & Formate)	1	3	1	2	3	1
Acetylene	1	1	1	1	1	X	Aluminum (Chloride & Fluoride)	1	1	1	2	1	1
Acetylene (Tetrabromide & Tetrachloride)	1	3	1	X	1	X	Aluminum Ethylate	1	X	X	X	X	X
Acetyl-o-Toluidine	1	X	X	X	X	X	Aluminum Hydroxide	1	2	1	2	2	X
Acetylsalicylic Acid	1	2	3	X	1	2	Aluminum Linoleate	1	1	3	2	1	1
Aconitic Acid	1	X	X	X	X	X	Aluminum Nitrate	1	1	1	2	1	X
Acridine	1	X	X	X	X	X	Aluminum Oxalate	1	3	1	2	3	1
Acrolein	1	3	1	2	3	1	Aluminum Phosphate	1	1	1	2	1	X
Acrylic Acid	1	2	3	X	1	2	Aluminum (Potassium Sulfate & Sodium Sulfate)	1	3	1	2	3	1
Acrylonitrile	1	3	3	3	3	3	Aluminum (Salts & Sulfate)	1	1	1	1	1	1
Adipic Acid	1	1	2	X	X	X	Alums-NH3 -Cr -K	1	1	1	1	3	3
Aero Lubriplate	1	1	3	2	1	1	Ambrex 33 (Mobil)	1	1	3	3	1	3
Aero Shell 17 Grease	1	1	3	2	1	1	Ambrex 830 (Mobil)	1	1	3	2	1	1
Aero Shell 750	1	2	3	3	1	2	Amines-Mixed	1	3	2	2	3	3
Aero Shell 7A Grease	1	2	3	2	1	1	Aminoantraquinone	1	X	X	X	X	X
Aero Shell IAC	1	1	3	2	1	1	p-Aminoazobenzene	1	X	X	X	X	X
Aerosafe (2300 & 2300W)	1	3	1	3	3	3	p-Aminobenzoic Acid (PABA)	1	3	2	X	2	X
Aerozene 50 (50% Hydrazine 50% UDMH)	2	3	1	3	3	3	p-Aminophenol	1	X	X	X	X	X

Chemical Compatibility Table

1 = recommended
 2 = marginal
 3 = unsatisfactory
 X = insufficient data

Compound	Temperature Range	Compound	Temperature Range
Fluoroelastomer (FKM)	-26°C to 205°C (-15°F to 400°F)	Nitrile (NBR)	-34°C to 121°C (-30°F to 250°F)
Fluorosilicone (FVMQ)	-73°C to 190°C (-100°F to 375°F)	Ethylene Propylene (EPDM)	-57°C to 149°C (-70°F to 300°F)
Perfluoroelastomer (FFKM)	-26°C to 316°C (-15°F to 600°F)	Silicone (VMQ)	-54°C to 232°C (-65°F to 450°F)

ALWAYS TEST UNDER ACTUAL SERVICE CONDITIONS.

Published Temperature ranges will apply to majority of media for which the material is recommended.

Fluid	Material						Fluid	Material					
	Perfluoroelastomer	Nitrile	Ethylene Propylene	Silicone	Fluoroelastomer	Fluorosilicone		Perfluoroelastomer	Nitrile	Ethylene Propylene	Silicone	Fluoroelastomer	Fluorosilicone
Ammonia	3	1	1	1	3	3	tert-Amyl Methyl Ether (TAME)	1	X	X	X	X	X
Ammonia and Lithium Metal in Solution	3	2	2	3	3	3	Amyl Naphthalene	1	3	3	3	1	1
Ammonia (Anhydrous & Liquid)	1	2	1	2	3	3	Amyl (Nitrate & Nitrite)	1	3	1	2	3	1
Ammonia Gas, Cold	1	1	1	1	3	3	o-sec-Amylphenol	1	X	X	X	X	X
Ammonia Gas, Hot	1	3	2	X	3	3	Anderol di-ester (L-826, L-829, & L-774)	1	2	3	3	1	2
Ammonium (Acetate, Arsenate, Bicarbonate)	1	3	1	2	3	1	ANG-25 (Di-ester Base) (TG749)	1	2	3	2	1	2
Ammonium Bifluoride	1	X	X	X	X	X	ANG-25 (Glycerol Ester)	1	2	1	2	1	2
Ammonium (Bisulfite, Carbamate, & Citrate)	1	3	1	2	3	1	Aniline	1	3	1	3	2	2
Ammonium (Carbonate & Chloride (2N))	1	3	1	X	1	X	Aniline Dyes	1	3	2	3	2	2
Ammonium (Bromide, Fluoride, & Iodide)	1	1	1	X	1	X	Aniline Hydrochloride	1	2	1	2	2	1
Ammonium (Dichromate & Diphosphate)	1	3	1	2	3	1	Aniline Oil	1	3	2	3	3	3
Ammonium Fluorosilicate	1	X	X	X	X	X	Aniline (Sulfate & Sulfite)	1	3	1	2	3	1
Ammonium Hydroxide, 3 Molar	X	1	1	1	3	1	Animal Fats	1	1	2	X	1	X
Ammonium Hydroxide, Concentrated	1	3	1	1	3	1	Animal Oil (Lard Oil)	1	1	2	2	1	1
Ammonium Hydrozide	X	1	1	1	1	1	Anisole	1	X	X	X	X	X
Ammonium (Metaphosphate, & Molybdenate)	1	3	1	2	3	1	Anisoyl Chloride	1	X	X	X	X	X
Ammonium (Lactate, Oxalate, & Perchlorate)	1	3	1	2	3	1	AN-O-3 Grade M	1	1	3	2	1	1
Ammonium Nitrate, 2N	1	1	1	X	X	X	AN-O-366	1	1	3	3	1	1
Ammonium (Nitrite & Mono-Basic)	1	1	1	2	X	X	AN-O-6	1	1	3	3	1	1
Ammonium Persulfate 10%	X	3	1	X	X	X	Ansul Ether	1	2	2	3	3	2
Ammonium Persulfate Solution	1	3	1	X	X	X	Ansul Ether 161 or 181	1	3	3	3	3	3
Ammonium Phosphate	1	1	1	1	3	X	Anthracene	1	2	3	X	1	2
Ammonium Phosphate (Dibasic & Tribasic)	1	1	1	1	X	X	Anthranilic Acid	1	X	X	X	X	X
Ammonium (Phosphite, Picrate, & Polysulfide)	1	3	1	2	3	1	Anthraquinone	1	X	X	X	X	X
Ammonium (Salicylate, Sulfamate, & Sulfite)	1	3	1	2	3	1	Antifreeze	1	1	1	1	1	X
Ammonium (Sulfate, Sulfate Nitrate, Sulfide)	1	1	1	X	3	X	Antimony (Chloride, Pentachloride, Tribromide)	1	1	3	3	1	1
Ammonium Salts	1	1	1	1	3	3	Antimony (Trichloride, Trifluoride, & Trioxide)	1	1	3	3	1	1
Ammonium (Thiocyanate & Thioglycolate)	1	3	1	2	3	1	Antimony Pentafluoride	2	X	X	X	X	X
Ammonium (Thiosulfate & Tungstate)	1	3	1	2	3	1	Antimony Sulfate	1	X	X	X	X	X
Amyl Acetate	1	1	2	3	3	3	AN-VV-O-366b Hydr. Fluid	1	1	3	3	1	1
Amyl Alcohol	1	2	1	3	2	1	Aqua Regia	1	3	3	X	2	X
Amyl Borate	1	1	3	X	1	X	Arachidic Acid	1	X	X	X	X	X
Amyl (Butyrate & Propionate)	1	1	3	2	1	1	Argon	1	1	1	1	1	1
Amyl Chloride	1	X	3	3	1	2	Aroclor, 1248	1	3	2	2	1	2
Amyl Chloronaphthalene	1	3	3	3	1	2	Aroclor, 1254	1	3	2	3	1	2
Amyl (Cinnamic Aldehyde & Laurate)	1	2	3	X	1	2	Aroclor, 1260	1	1	X	1	1	1
Amyl Mercaptan	1	2	3	X	1	2	Aroclors	1	2	1	2	1	2

Chemical Compatibility Table

1 = recommended
 2 = marginal
 3 = unsatisfactory
 X = insufficient data

Compound	Temperature Range	Compound	Temperature Range
Fluoroelastomer (FKM)	-26°C to 205°C (-15°F to 400°F)	Nitrile (NBR)	-34°C to 121°C (-30°F to 250°F)
Fluorosilicone (FVMQ)	-73°C to 190°C (-100°F to 375°F)	Ethylene Propylene (EPDM)	-57°C to 149°C (-70°F to 300°F)
Perfluoroelastomer (FFKM)	-26°C to 316°C (-15°F to 600°F)	Silicone (VMQ)	-54°C to 232°C (-65°F to 450°F)

ALWAYS TEST UNDER ACTUAL SERVICE CONDITIONS.

Published Temperature ranges will apply to majority of media for which the material is recommended.

Fluid	Material						Fluid	Material					
	Perfluoroelastomer	Nitrile	Ethylene Propylene	Silicone	Fluoroelastomer	Fluorosilicone		Perfluoroelastomer	Nitrile	Ethylene Propylene	Silicone	Fluoroelastomer	Fluorosilicone
Aromatic Fuel -50%	1	2	3	3	1	2	Benzenesulfonic Acid 10%	1	3	3	3	1	2
Arsenic (Trichloride, Trioxide, & Trisulfide)	1	1	3	X	3	X	Benzidine	1	2	3	X	1	2
Arsenic Acid	1	1	1	1	1	1	Benzidine 3 Sulfonic Acid	1	2	3	X	1	2
Arsine	1	X	X	X	X	X	Benzil	1	2	3	X	1	2
Ascorbic Acid	1	3	1	2	3	1	Benzilic Acid	1	2	3	X	1	2
Askarel Transformer Oil	1	1	3	3	1	2	Benzine	X	1	3	3	1	1
Aspartic Acid	1	3	1	2	3	1	Benzine (Ligroin)	1	1	3	3	1	1
Asphalt	1	2	3	3	1	2	Benzocatechol	X	2	3	X	1	2
Aspirin	1	X	X	X	X	X	Benzochloride	X	3	1	X	1	1
ASTM Fuel (A & B)	1	1	3	3	1	1	Benzoic Acid	1	3	3	3	1	2
ASTM Fuel C	1	1	3	3	1	2	Benzoin	1	2	3	X	1	2
ASTM Fuel D	1	2	3	3	1	X	Benzonitrile	1	3	1	2	3	1
ASTM Oil, No.1	1	1	3	1	1	1	Benzophenone	X	3	1	3	1	1
ASTM Oil, No. (2 & 3)	1	1	3	3	1	1	Benzophenone	1	X	2	X	1	1
ASTM Oil, No.4	1	2	3	3	1	2	Benzoquinone	1	X	2	X	1	X
ASTM Oil, No.5	1	1	3	X	1	X	Benzotri- (chloride & fluoride)	1	3	1	X	1	X
ATL-857	X	2	3	3	1	2	Benzoyl Chloride	1	X	X	X	1	2
Atlantic (Dominion F & Utro Gear-EP Lube)	X	1	3	3	1	1	Benzoylsulfonic Acid	1	2	3	X	1	2
Atlantic Utro Gear-e	X	1	3	X	1	X	Benzyl Alcohol	1	3	2	2	1	2
Aurex 903R (Mobil)	1	1	3	3	1	3	Benzyl (Acetate & Butyl Phthalate)	1	3	1	2	3	1
Automatic Transmission Fluid	1	1	3	3	1	X	Benzylamine	1	X	X	X	X	X
Automotive Brake Fluid	1	3	1	3	3	3	Benzyl (Benzoate, Bromide, & Chloride)	1	3	3	3	1	1
Azobenzene	1	X	X	X	X	X	Benzyl (Phenol, p-phenol, & Salicylate)	1	2	3	X	1	2
Bardol B	1	3	3	3	1	2	Beryllium (Chloride, Fluoride, & Oxide)	1	1	1	3	1	3
Barium (Carbonate, Chlorate, & Nitrate)	1	3	1	2	3	1	Beryllium Sulfate	1	3	1	2	3	1
Barium (Peroxide, & Polysulfide)	1	3	1	2	3	1	Bezyl Alcohol	1	3	1	X	1	2
Barium (Chloride, Cyanide, Iodide, & Sulfide)	1	1	1	1	1	1	Bismuth (Carbonate, Nitrate, & Oxychloride)	1	3	1	2	3	1
Barium (Hydroxide & Oxide)	1	1	1	1	1	1	Bittern	1	X	X	X	X	X
Barium Sulfate	1	1	1	X	1	X	Black Liquor	3	2	1	X	1	X
Bayol (35 & D)	1	1	3	3	1	1	Black Point 77	1	1	1	3	1	3
Beer	X	1	1	1	1	1	Blast Furnace Gas	1	3	3	1	1	2
Beet Sugar Liquids	X	1	1	X	1	X	Bleach	X	1	1	3	1	2
Beet Sugar Liquors	1	1	1	1	1	1	Bleach Liquor	1	3	1	2	1	2
Benz- (amide & anthrone)	1	2	3	X	1	2	Bleach Solutions	1	X	1	X	1	X
Benzaldehyde	2	1	1	1	1	1	Bone Oil	1	1	2	X	1	X
Benzene	1	3	1	3	1	3	Borane	1	X	X	X	X	X
Benzene Hexachloride (BHC)	1	X	X	X	X	X	Borax	1	2	1	2	1	2

Chemical Compatibility Table

1 = recommended
 2 = marginal
 3 = unsatisfactory
 X = insufficient data

Compound	Temperature Range	Compound	Temperature Range
Fluoroelastomer (FKM)	-26°C to 205°C (-15°F to 400°F)	Nitrile (NBR)	-34°C to 121°C (-30°F to 250°F)
Fluorosilicone (FVMQ)	-73°C to 190°C (-100°F to 375°F)	Ethylene Propylene (EPDM)	-57°C to 149°C (-70°F to 300°F)
Perfluoroelastomer (FFKM)	-26°C to 316°C (-15°F to 600°F)	Silicone (VMQ)	-54°C to 232°C (-65°F to 450°F)

ALWAYS TEST UNDER ACTUAL SERVICE CONDITIONS.

Published Temperature ranges will apply to majority of media for which the material is recommended.

Fluid	Material						Fluid	Material					
	Perfluoroelastomer	Nitrile	Ethylene Propylene	Silicone	Fluoroelastomer	Fluorosilicone		Perfluoroelastomer	Nitrile	Ethylene Propylene	Silicone	Fluoroelastomer	Fluorosilicone
Borax Solutions	1	X	1	X	1	X	Butadiene (Monomer)	1	3	3	3	1	1
Bordeaux Mixture	1	2	1	2	1	2	Butane	1	1	1	3	1	1
Boric Acid	1	1	1	1	1	1	Butane (2-Dimethyl & 3-Dimethyl)	X	1	3	3	1	3
Boric Oxide	1	3	1	2	3	1	Butanediol	1	3	1	2	3	1
Borneol	1	2	3	X	1	2	Butanol (Butyl Alcohol)	X	1	2	2	1	1
Bornyl (Acetate, Chloride, & Formate)	1	2	3	X	1	2	Butene 2-Ethyl (1-Butene 2-Ethyl)	X	1	3	3	1	3
Boron Fluids (HEF)	1	2	3	3	1	2	Butler	X	1	1	1	1	1
Boron (Phosphate, Tribromide, & Trichloride)	1	X	X	X	X	X	Butter-Animal Fat	X	1	1	2	1	1
Boron (Trifluoride, & Trioxide)	1	X	X	X	X	X	Butyl Acetate or n-Butyl Acetate	1	3	2	3	3	3
Brake Fluid (non Petroleum)	X	3	1	1	3	3	Butyl Acetyl Ricinoleate	1	2	1	X	1	2
Brake Fluid DOT3 (Glycol Type)	X	3	1	3	3	3	Butyl Acrylate or n-Butyl Acrylate	1	3	1	2	3	3
Bray GG-130	X	2	3	3	1	2	Butyl Alcohol or n-Butyl Alcohol	1	1	1	1	1	1
Brayco 719-R (VV-H-910)	1	3	1	2	3	2	Butyl Alcohol (Secondary & Tertiary)	1	2	2	2	1	2
Brayco 885 (MIL-L-6085A)	X	2	3	3	1	2	Butyl Amine or N-Butyl Amine	1	1	3	1	3	3
Brayco 910	1	2	1	3	3	3	Butyl Benzoate or n-Butyl Benzoate	1	3	1	X	1	1
Bret 710	X	2	1	3	3	3	Butyl Butyrate or n-Butyl Butyrate	1	3	1	X	1	1
Brine	1	1	1	X	1	X	Butyl Benzoate	1	3	1	2	3	1
Brom - 113	X	3	3	3	X	X	Butyl Benzyl Phthalate (BBP)	1	X	X	X	X	X
Brom - 114	X	2	3	3	2	X	Butyl Carbitol	1	3	2	3	2	3
Bromic Acid	1	3	1	2	3	1	p-tert-Butylcatechol	1	3	2	X	1	1
Bromine	1	3	3	3	1	2	Butyl Cellosolve	1	2	2	X	3	3
Bromine (Pentafluoride & Trifluoride)	2	3	3	3	3	3	Butyl Cellosolve Acetate	1	3	1	2	3	1
Bromine Water	1	3	2	3	1	2	Butyl Cellosolve Adipate	X	3	2	2	2	2
Bromobenzene	1	3	3	3	1	1	Butyl Chloride or n-Butyl Chloride	1	1	3	2	1	1
Bromobenzene Cyanide	1	3	1	2	3	1	Butyl Ether or n-Butyl Ether	1	3	3	3	3	3
Bromochloro Trifluoroethane (Halothane)	1	3	3	3	1	2	Butyl (Glycolate, Lactate, Laurate, & Oxalate)	1	3	1	2	3	1
Bromochloromethane	1	3	2	3	1	2	Butyl Methacrylate (n-Butyl Methacrylate)	1	3	1	2	3	1
Bromochloropropane	1	X	X	X	X	X	Butyl Mercaptan (Tertiary)	1	3	3	3	1	X
Bromoform	1	2	3	X	1	2	p-tert-Butylphenol	1	X	X	X	X	X
Bromomethane (Methyl Bromide)	1	2	3	X	1	1	Butyl Oleate	1	3	2	X	1	2
Bromotrifluoroethylene (BFE)	1	X	X	X	X	X	Butyl Stearate	1	2	3	X	1	2
Bromotrifluoromethane (FC 13B1)	2	1	1	3	1	2	Butylbenzoic Acid	1	2	3	X	1	2
Brucine Sulfate	1	3	1	2	3	1	Butylene	1	2	3	3	1	2
Buffered Oxide Etchants (BOE)	1	X	X	X	X	X	Butyraldehyde	2	3	2	3	3	3
Bunker	X	1	3	3	1	1	Butyric Acid	1	3	2	X	2	X
Bunker Oil	X	1	3	2	1	1	Butyric Anhydride	1	3	1	2	3	1
Bunker's C (Fuel Oil)	1	1	X	X	1	X	Butyrolacetone	1	3	1	2	3	1

Chemical Compatibility Table

1 = recommended
 2 = marginal
 3 = unsatisfactory
 X = insufficient data

Compound	Temperature Range	Compound	Temperature Range
Fluoroelastomer (FKM)	-26°C to 205°C (-15°F to 400°F)	Nitrile (NBR)	-34°C to 121°C (-30°F to 250°F)
Fluorosilicone (FVMQ)	-73°C to 190°C (-100°F to 375°F)	Ethylene Propylene (EPDM)	-57°C to 149°C (-70°F to 300°F)
Perfluoroelastomer (FFKM)	-26°C to 316°C (-15°F to 600°F)	Silicone (VMQ)	-54°C to 232°C (-65°F to 450°F)

ALWAYS TEST UNDER ACTUAL SERVICE CONDITIONS.

Published Temperature ranges will apply to majority of media for which the material is recommended.

Fluid	Material						Fluid	Material					
	Perfluoroelastomer	Nitrile	Ethylene Propylene	Silicone	Fluoroelastomer	Fluorosilicone		Perfluoroelastomer	Nitrile	Ethylene Propylene	Silicone	Fluoroelastomer	Fluorosilicone
Butyryl Chloride	1	2	3	X	1	2	Carbamate	1	3	2	X	1	1
Cadmium (Chloride, Cyanide, Nitrate, Oxide)	1	3	1	2	3	1	Carbitol	1	1	1	1	1	2
Cadmium (Sulfate, Sulfide, & Hydrosulfide)	1	3	1	2	3	1	Carbitol Acetate	X	3	3	3	1	X
Calcine Liquors	1	1	1	X	1	1	Carbolic Acid (Phenol)	1	3	2	3	1	1
Calcium Acetate	1	2	1	3	3	3	Carbon (Bisulfide & Disulfide)	1	3	3	3	1	1
Calcium (Arsenate, Bicarbonate, & Bisulfide)	1	3	1	2	3	1	Carbon Dioxide (Explosive Decompression Use)	1	1	1	1	1	1
Calcium Bisulfite	1	2	1	3	2	3	Carbon Fluorides	1	2	3	3	1	2
Calcium (Benzoate, Stearate, & Sulfamate)	1	2	3	X	1	2	Carbon Monoxide	1	1	1	1	1	2
Calcium (Bromide, Chloride, & Fluoride)	1	1	1	1	1	1	Carbon (Tetrachloride & Tetrafluoride)	1	2	3	3	1	2
Calcium (Hydride, Oxide, Sulfide, & Sulfite)	1	1	1	1	1	1	Carbon Tetrabromide	1	X	X	X	X	X
Calcium Carbide	1	X	X	X	X	X	Carbonic Acid	1	1	1	1	1	1
Calcium Carbonate	1	1	1	1	1	1	Casein	1	3	1	2	3	1
Calcium Cyanamide	1	X	X	X	X	X	Castor Oil	1	1	1	1	1	1
Calcium Cyanide	1	1	1	1	X	X	Caustic (Lime, Potash, & (Sodium Hydroxide))	1	3	1	2	3	1
Calcium (Chlorate, Chromate, & Gluconate)	1	3	1	2	3	1	Cellosolve	1	3	2	3	3	3
Calcium Hydrogen Sulfite	1	3	3	1	1	1	Cellosolve (Butyl & Acetate)	1	3	2	3	3	3
Calcium Hydroxide	1	1	1	1	1	1	Cellugard	1	1	1	1	1	1
Calcium Hypochlorite	1	2	1	2	1	2	Cellulose (Acetate & Acetate Butyrate)	1	3	1	2	3	1
Calcium (Hypophosphite, Lactate, & Oxalate)	1	3	1	2	3	1	Cellulose (Ether, Nitrate, & Tripropionate)	1	3	1	2	3	1
Calcium Nitrate	1	1	1	2	1	1	CELLULUBE (Phosphate Esters)	1	3	1	1	1	3
Calcium (Permanganate & Peroxide)	1	X	X	X	X	X	CELLULUBE A60	1	3	2	2	3	3
Calcium Phosphate	1	1	1	1	1	X	Cellutherm 2505A	1	2	3	3	1	2
Calcium (Phenolsulfonate, & Phosphate Acid)	1	3	1	2	3	1	Cement, Portland	1	1	1	X	1	X
Calcium (Propionate, Sulfate, & Thiocyanate)	1	3	1	2	3	1	Ceric Sulfate	1	X	X	X	X	X
Calcium Salts	1	1	1	2	1	1	Cerium Sulfate	1	3	1	2	3	1
Calcium Silicate	1	1	1	X	1	X	Cerous (Chloride, Fluoride, & Nitrate)	1	3	1	2	3	1
Calcium Thiosulfate	1	2	1	1	1	1	Cetane (Hexadecane or n-Hexadecane)	1	1	3	3	1	3
Calcium Tungstate	1	3	1	2	3	1	Cetyl Alcohol	1	1	3	2	1	1
Caliche Liquors	1	1	1	2	1	1	Chassis Grease	X	1	2	3	1	X
Camphene	1	2	3	X	1	2	Chaulmoogric Acid	1	X	X	X	X	X
Camphor	1	2	3	X	1	2	China Wood Oil (Tung Oil)	1	1	3	3	1	2
Camphoric Acid	1	2	3	X	1	2	Chloracetic Acid	X	3	3	X	3	3
Cane Sugar Liquors	1	1	1	1	1	1	Chloracetone	X	3	2	3	1	X
Capric & Caproic Acid	1	1	3	2	1	1	Chloral	1	3	1	2	3	1
Caproic Aldehyde	1	X	2	2	3	3	Cloramine	1	X	X	X	X	X
Caprolactam	1	1	3	2	1	1	Chloranthraquinone	1	2	3	X	1	2
Capronaldehyde	1	1	3	2	1	1	Chlordane	1	1	2	3	1	2

Chemical Compatibility Table

1 = recommended
 2 = marginal
 3 = unsatisfactory
 X = insufficient data

Compound	Temperature Range	Compound	Temperature Range
Fluoroelastomer (FKM)	-26°C to 205°C (-15°F to 400°F)	Nitrile (NBR)	-34°C to 121°C (-30°F to 250°F)
Fluorosilicone (FVMQ)	-73°C to 190°C (-100°F to 375°F)	Ethylene Propylene (EPDM)	-57°C to 149°C (-70°F to 300°F)
Perfluoroelastomer (FFKM)	-26°C to 316°C (-15°F to 600°F)	Silicone (VMQ)	-54°C to 232°C (-65°F to 450°F)

ALWAYS TEST UNDER ACTUAL SERVICE CONDITIONS.

Published Temperature ranges will apply to majority of media for which the material is recommended.

Fluid	Perfluoroelastomer						Fluid	Perfluoroelastomer					
	Nitrile	Ethylene Propylene	Silicone	Fluoroelastomer	Fluorosilicone	Nitrile		Ethylene Propylene	Silicone	Fluoroelastomer	Fluorosilicone		
Chlorextol	1	2	3	3	1	2	Chloronaphthalene or o-Chloronaphthalene	1	3	3	3	1	2
Chloric Acid	1	3	1	2	3	1	Chloronitrobenzene	1	3	1	2	3	1
Chlorinated Solvents (Dry & Wet)	1	3	3	3	1	1	Chloronitroethane	1	3	3	3	3	3
Chlorine	1	3	3	X	1	1	Chloropentafluoroethane (FC 115)	2	1	1	X	1	X
Chlorine Dioxide	2	3	3	X	1	2	Chlorophenol (o-Chlorophenol & p-Chlorophenol)	1	3	3	3	1	2
Chlorine Dioxide 8% Cl as NaClO2	X	3	3	X	1	2	Chloropicrin	1	X	X	X	X	X
Chlorine Trifluoride	2	3	3	3	3	3	Chloroprene	1	3	3	3	1	2
Chlorine Water	1	3	2	X	1	X	Chlorosulfonic Acid	1	3	3	3	3	3
Chlorine, Dry	1	3	X	3	2	X	Chlorotetrafluoroethane (FC 124)	2	X	X	X	X	X
Chlorine, Wet	1	3	X	3	2	X	Chlorotoluene or p-Chlorotoluene	1	3	3	3	1	2
Chloro- (picrin, prene, & toluidine)	1	2	3	X	1	2	Chlorotoluene Sulfonic Acid	1	3	1	2	3	1
Chloro (1-Nitro Ethane 1-Chloro-1-Nitro Ethane)	1	3	3	3	3	3	Chlorotrifluoromethane (FC 13)	2	X	1	3	1	3
Chloro Xylenols	1	2	3	X	1	2	Chlorotritluoroethylene (CTFE)	2	X	X	X	X	X
Chloroacetaldehyde	2	3	1	2	3	1	Chlorox	1	2	2	X	1	1
Chloroacetic Acid	1	3	2	X	3	3	Chloroxylenol	1	X	X	X	X	X
Chloroacetone	1	3	1	3	3	3	Cholesterol	1	2	3	X	1	2
Chloroacetyl Chloride	1	X	X	X	X	X	Choline	1	X	X	X	X	X
Chloroamino Benzoic Acid	1	3	1	2	3	1	Chrome Alum	1	1	1	1	1	X
Chloroaniline	1	3	1	2	3	1	Chrome Plating Solutions	1	3	2	2	1	2
Chlorobenzaldehyde	1	3	1	2	3	1	Chromic Acid	1	3	2	X	1	2
Chlorobenzene (Chlorobenzene (Mono))	1	3	3	3	1	2	Chromic (Chloride, Fluoride, Hydroxide)	1	X	X	X	X	X
Chlorobenzene (Chloride & Trifluoride)	1	2	3	X	1	2	Chromic Oxide	1	3	2	X	1	X
Chlorobenzo- (chloride & trifluoride)	1	2	3	X	1	2	Chromic (Nitrate, Phosphate & Sulfate)	1	X	X	X	X	X
Chlorobenzol	X	3	3	3	1	X	Chromium Potassium Sulfate (Alum)	1	2	2	X	1	X
Chlorobromomethane	1	3	2	3	1	2	Chromyl Chloride	1	X	X	X	X	X
Chlorobromopropane	1	2	3	X	1	2	Cinnamic (Acid, Alcohol, & Aldehyde)	1	2	3	X	1	2
Chlorobutadiene	X	3	3	3	1	2	Circo Light Process Oil	1	1	3	3	1	1
Chlorobutane (Butyl Chloride)	1	1	3	2	1	1	Citric Acid	1	1	1	1	1	1
Chlorodifluoroethane (FC 142b)	2	X	1	X	3	X	City Service (#65, #120, #250, Pacemaker #2)	1	1	3	3	1	1
Chlorodifluoromethane (FC 22)	1	3	2	3	3	3	City Service (Koolmoter AP Gear Oil 140-EP)	1	1	3	3	1	1
Chlorododecane	1	3	3	3	1	1	Clorox	1	2	2	X	1	X
Chloroethane	1	1	3	2	1	1	Coal Tar	1	1	X	X	1	X
Chloroethane Sulfonic Acid	1	3	1	2	3	1	Cobalt Chloride	X	1	1	2	1	1
Chloroethylbenzene	1	2	3	X	1	2	Cobalt Chloride, 2N	X	1	1	1	1	1
Chloroform	1	3	3	3	1	2	Cobaltous (Acetate & Sulfate)	1	3	1	2	3	1
Chlorohydrin	1	3	1	2	3	1	Cobaltous Bromide	1	1	1	1	1	1

Chemical Compatibility Table

1 = recommended
 2 = marginal
 3 = unsatisfactory
 X = insufficient data

Compound	Temperature Range	Compound	Temperature Range
Fluoroelastomer (FKM)	-26°C to 205°C (-15°F to 400°F)	Nitrile (NBR)	-34°C to 121°C (-30°F to 250°F)
Fluorosilicone (FVMQ)	-73°C to 190°C (-100°F to 375°F)	Ethylene Propylene (EPDM)	-57°C to 149°C (-70°F to 300°F)
Perfluoroelastomer (FFKM)	-26°C to 316°C (-15°F to 600°F)	Silicone (VMQ)	-54°C to 232°C (-65°F to 450°F)

ALWAYS TEST UNDER ACTUAL SERVICE CONDITIONS.

Published Temperature ranges will apply to majority of media for which the material is recommended.

Fluid	Material						Fluid	Material					
	Perfluoroelastomer	Nitrile	Ethylene Propylene	Silicone	Fluoroelastomer	Fluorosilicone		Perfluoroelastomer	Nitrile	Ethylene Propylene	Silicone	Fluoroelastomer	Fluorosilicone
Cobaltous Chloride	1	1	1	2	1	1	Cyanohydrin	1	X	X	X	X	X
Cobaltous Linoleate	1	X	X	X	X	X	Cyanuric Chloride	1	X	X	X	X	X
Coconut Oil	1	1	3	1	1	1	Cyclo- (hexene & pentadiene)	1	2	3	X	1	2
Cod Liver Oil	1	1	1	1	1	1	Cyclohexane	1	1	2	3	1	1
Codeine	X	2	3	X	1	2	Cyclohexanol	1	1	1	3	1	1
Coffee	X	1	1	1	1	1	Cyclohexanone	1	3	2	3	3	3
Coke Oven Gas	1	3	3	2	1	2	Cyclohexylamine (Cyclohexylamine Laurate)	1	1	3	2	1	1
Coliche Liquors	X	2	2	X	X	X	Cyclo- (pentane & polyolefins)	1	1	3	3	1	1
Convelex 10	1	3	X	3	X	X	Cyclopropane	1	X	X	X	X	X
Coolanol 20 25R 35R 40& 45A (Monsanto)	1	1	3	3	1	1	Cymene or p-Cymene	1	3	3	3	1	2
Copper Acetate	1	2	1	3	3	3	DDT (Dichlorodiphenyltrichloroethane)	1	2	3	X	1	2
Copper (Ammonium Acetate, & Carbonate)	1	3	1	2	3	1	Decahydronaphthalene	1	3	3	3	1	1
Copper Gluconate	1	3	1	2	3	1	Decalin	X	3	3	3	1	1
Copper (Chloride, Cyanide, Oxide, Sulfate)	1	1	1	1	1	1	Decane or n-Decane	1	1	3	2	1	1
Copper Nitrate	1	2	2	X	1	X	Deionized Water	1	2	2	X	1	X
Copper Sulfate (10% & 50%)	1	1	1	1	1	1	Delco Brake Fluid	1	3	1	3	3	3
Corn Oil	1	1	3	1	1	1	Denatured Alcohol	1	1	1	1	1	1
Cottonseed Oil	1	1	3	1	1	2	Detergent, Water Solution	1	1	1	1	1	1
Creosote	X	1	1	3	1	1	Developing Fluids (Photo)	1	1	2	1	1	1
Creosote Oil	1	1	2	2	1	X	Dexron	X	1	3	3	1	2
Creosote (Coal Tar & Wood)	1	1	3	3	1	1	Dextrin	1	1	3	2	1	1
Cresylic Acid	1	3	3	3	1	2	Dextro Lactic Acid	1	3	1	2	3	1
Cresol (Methyl Phenol)	1	X	X	X	1	X	Dextron	1	1	3	X	1	X
Cresols	X	3	3	3	2	X	Dextrose	1	3	1	2	3	1
Cresylic Acid	1	3	3	3	1	X	DI Water	X	2	1	2	2	1
Crotonaldehyde	1	2	3	X	1	2	Diacetone	1	3	1	3	3	3
Crotonic Acid	1	2	3	X	1	2	Diacetone Alcohol	1	3	1	3	3	3
Crude Oil	1	1	3	3	1	2	Dialkyl Sulfates	1	3	1	2	3	1
Cumaldehyde	1	2	3	X	1	2	Diallyl Phthalate (DAP)	1	X	X	X	X	X
Cumene	1	3	3	3	1	2	Diamylamine	1	1	3	2	1	1
Cumene Hydroperoxide	1	X	X	X	X	X	Diazinon	1	3	3	3	2	2
Cuminic Aldehyde	1	X	X	X	X	X	Dibenzyl (sym-Diphenylethane)	1	2	3	X	1	2
Cupric Sulfate	1	2	2	X	1	X	Dibenzyl Ether	1	3	2	X	3	X
Cutting Oil	1	1	3	3	1	1	Dibenzyl Sebacate	1	3	2	3	2	3
Cyanamide	1	X	X	X	X	X	Diborane	1	X	X	X	X	X
Cyanoacetic Acid	1	X	X	X	X	X	Dibromodifluoromethane	1	3	2	3	X	X
Cyanogen Chloride	1	3	3	X	2	X	Dibromoethane	1	2	3	X	1	2

Chemical Compatibility Table

1 = recommended
 2 = marginal
 3 = unsatisfactory
 X = insufficient data

Compound	Temperature Range	Compound	Temperature Range
Fluoroelastomer (FKM)	-26°C to 205°C (-15°F to 400°F)	Nitrile (NBR)	-34°C to 121°C (-30°F to 250°F)
Fluorosilicone (FVMQ)	-73°C to 190°C (-100°F to 375°F)	Ethylene Propylene (EPDM)	-57°C to 149°C (-70°F to 300°F)
Perfluoroelastomer (FFKM)	-26°C to 316°C (-15°F to 600°F)	Silicone (VMQ)	-54°C to 232°C (-65°F to 450°F)

ALWAYS TEST UNDER ACTUAL SERVICE CONDITIONS.

Published Temperature ranges will apply to majority of media for which the material is recommended.

Fluid	Perfluoroelastomer						Fluid	Perfluoroelastomer					
	Nitrile	Ethylene Propylene	Silicone	Fluoroelastomer	Fluorosilicone	Nitrile		Ethylene Propylene	Silicone	Fluoroelastomer	Fluorosilicone		
Dibromomethyl Benzene	1	3	3	3	1	2	Diethyl Benzene	1	2	3	X	1	X
Dibromotetrafluoroethane (FC 114B2)	2	2	3	3	2	X	Diethyl Carbonate	1	3	1	2	3	1
Dibutyl Amine or n-Dibutyl Amine	1	3	2	3	3	3	Diethyl Ether	1	3	3	3	3	3
Dibutyl Cellosolve Adipate	1	3	1	2	3	1	Diethyl Phthalate	1	2	3	X	1	2
Dibutyl Ether	1	3	3	3	3	3	Diethyl Sebacate	1	2	2	2	2	2
Dibutyl Phthalate	1	3	2	2	3	3	Diethyl Sulfate	1	3	1	2	3	X
Dibutyl Sebacate	1	3	2	2	2	2	Diethylamine	1	1	1	1	3	3
Dibutyl tert-Peroxide	1	X	X	X	X	X	Diethylaniline or n-Diethylaniline	1	3	1	2	3	1
Dibutyl Methylenedithio Glycolate	1	2	3	X	1	2	Diethylene Glycol	1	1	1	1	1	1
Dibutyl (Thioglycolate, & Thiourea)	1	2	3	X	1	2	Diethylene Glycol Butyl Ether	1	3	1	3	3	3
Dicapryl Phthalate	1	3	2	3	2	2	Diethylene Glycol Methyl Ether	1	X	X	X	X	X
Dichloroacetic Acid	1	2	3	X	1	2	Diethylenetriamine	1	X	X	X	X	X
Dichloroaniline	1	3	1	2	3	1	Diethylhexyl Phthalate	1	3	2	3	2	2
Dichlorobenzene	1	3	3	3	1	2	Diethylhexyl Sebacate	1	3	2	3	2	3
o-Dichlorobenzene or p-Dichlorobenzene	1	3	3	3	1	2	Diethylhexylamine	1	X	X	X	X	X
Dichlorobutane	1	2	3	3	1	2	Difluoro- (ethane & monochloroethane)	1	2	3	X	1	2
Dichlorobutene	1	X	X	X	X	X	Difluorodibromomethane	1	3	2	3	X	X
Dichlorodiphenyl-Dichloroethane (DDD)	1	2	3	X	1	2	Diglycol Chloroformate	1	3	1	2	3	1
Dichlorodiethyl Sulfide	1	X	1	1	X	X	Diglycolic Acid	1	3	1	2	3	1
Dichlorodifluoromethane (FC 12)	2	1	2	3	2	3	Dihydroxydiphenylsulfone	1	3	1	2	3	1
Dichlorofluoroethane (FC 141b)	1	X	X	X	X	X	Diisobutyl Ketone	1	X	1	X	X	X
Dichlorofluoromethane (FC 21)	1	3	3	3	3	X	Diisobutylcarbinol	1	1	3	2	1	1
Dichlorohydrin	1	3	1	2	3	1	Diisobutylene	1	2	3	3	1	3
Dichloroisopropyl Ether	1	3	3	3	3	3	Diisooctyl Sebacate (DIOS)	1	3	3	3	2	3
Dichloro- (ethane, ethylene, & methane)	1	2	3	X	1	2	Diisopropyl- (benzene & idene Acetone)	1	2	3	X	1	2
Dichloro- (phenol & phenoxyacetic Acid)	1	2	3	X	1	2	Diisopropyl Ketone	1	3	1	3	3	3
Dichloro- (propane & propene)	1	2	3	X	1	2	Dimethyl	1	3	1	X	1	X
Dichlorosilane	1	X	X	X	X	X	Dimethyl (Acetamide & Formaldehyde)	1	3	1	2	3	1
Dichlorotetrafluoroethane (FC 114)	2	1	1	3	1	2	Dimethyl Disulfide (DMDS)	1	1	3	2	1	1
Dichlorotrifluoroethane (FC 123)	1	X	X	X	X	X	Dimethyl Ether	1	1	2	X	2	X
Dicyclohexylamine	1	1	3	2	3	3	Dimethyl Formamide (DMF)	1	3	1	1	3	X
Dicyclohexylammonium Nitrate	1	3	1	2	3	1	Dimethyl Aniline (Xylidine)	1	2	3	X	1	2
Dieldrin (HEOD)	1	2	3	X	1	2	Dimethyl (Phenyl Carbinol, Phenyl Methanol)	1	2	3	X	1	2
Diesel Oil	1	1	2	3	1	1	Dimethyl (Hydrazine & Sulfoxide (DMSO))	1	3	1	2	3	1
Di-ester Lubricant MIL-L-7808	1	2	3	3	1	2	Dimethyl Phthalate	1	3	2	X	2	2
Di-ester Synthetic Lubricants	1	2	3	3	1	2	Dimethyl Terephthalate (DMT)	1	2	3	X	1	2
Diethanolamine (DEA)	1	3	1	2	3	1	Dimethylamine (DMA)	2	2	1	2	3	3

Chemical Compatibility Table

1 = recommended
 2 = marginal
 3 = unsatisfactory
 X = insufficient data

Compound	Temperature Range	Compound	Temperature Range
Fluoroelastomer (FKM)	-26°C to 205°C (-15°F to 400°F)	Nitrile (NBR)	-34°C to 121°C (-30°F to 250°F)
Fluorosilicone (FVMQ)	-73°C to 190°C (-100°F to 375°F)	Ethylene Propylene (EPDM)	-57°C to 149°C (-70°F to 300°F)
Perfluoroelastomer (FFKM)	-26°C to 316°C (-15°F to 600°F)	Silicone (VMQ)	-54°C to 232°C (-65°F to 450°F)

ALWAYS TEST UNDER ACTUAL SERVICE CONDITIONS.

Published Temperature ranges will apply to majority of media for which the material is recommended.

Fluid	Material						Fluid	Material					
	Perfluoroelastomer	Nitrile	Ethylene Propylene	Silicone	Fluoroelastomer	Fluorosilicone		Perfluoroelastomer	Nitrile	Ethylene Propylene	Silicone	Fluoroelastomer	Fluorosilicone
Dinitrochlorobenzene	1	2	3	X	1	2	Esam-6 Fluid	1	X	1	X	3	3
Dinitrotoluene (DNT)	1	3	3	3	3	3	Esso (Fuel 208 & Transmission Fluid (Type A))	1	1	3	3	1	1
Diethyl Phthalate	1	3	1	2	1	2	Esso Golden Gasoline	1	2	3	3	1	1
Diethyl Sebacate	1	3	2	3	2	3	Esso (Motor Oil & WS2812 (MIL-L-7808A))	1	1	3	3	1	1
Diethylamine	1	1	3	2	1	1	Esso XP90-EP lubricant	1	1	3	3	1	1
Dioxane	1	3	1	3	3	3	Esstic 42, 43	1	1	3	3	1	1
Dioxolane	1	3	2	3	3	3	Ethane	1	1	3	3	1	2
Dipentene	1	2	3	3	1	2	Ethanol+D30	1	3	3	3	2	X
Diphenyl (Diphenyl Oxides)	1	3	3	3	1	2	Ethanol	1	1	1	1	1	1
Diphenylamine (DPA)	1	2	3	X	1	2	Ethanol Amine (MEA)	1	2	1	2	3	3
Diphenylene Oxide	1	X	X	X	X	X	Ethers	1	3	3	3	3	3
sym-Diphenylethane	1	X	X	X	X	X	Ethoxyethyl Acetate (EGMEEA)	X	3	1	2	3	1
Diphenylpropane	1	2	3	X	1	2	Ethyl Acetate	1	3	1	1	3	3
Disilane	1	X	X	X	X	X	Ethyl Alcohol	1	3	1	2	3	1
Dodecylbenzene	1	2	3	X	1	2	Ethyl Aluminum Dichloride	1	X	X	X	X	X
n-Dodecyl Mercaptan	1	X	X	X	X	X	Ethyl Acetate-Organic Ester	1	3	2	2	3	3
Dow Chemical 50-4	2	X	1	X	3	3	Ethyl (Acetoacetate & Acrylate)	1	3	2	2	3	3
Dow Chemical ET378	2	3	X	3	X	X	Ethyl (Benzene & Benzoate)	1	3	3	3	1	1
Dow Chemical ET588	2	3	1	X	3	3	Ethyl Bromide	1	2	3	X	1	1
Dow Corning (1208, 4050, 6620, F-60, 61, xF-60, 220)	1	1	1	X	1	X	Ethyl Butyrate	1	X	X	X	X	X
Dow Corning (-3, -4, & -11)	1	2	1	2	1	1	Ethyl (Cellosolve & Chloroformate)	1	3	2	3	3	3
Dow Corning (-33, -44, -5, -510, & -55)	1	2	1	3	1	2	Ethyl Cellulose	1	1	1	1	3	3
Dow Corning (-550, -704, -705, & -710)	1	2	1	3	1	2	Ethyl Chloride	1	1	3	3	1	1
Dow Corning -1265 Fluorosilicone Fluid	X	2	1	1	1	3	Ethyl Chlorocarbonate	1	3	2	3	1	2
Dow Corning -200	X	2	1	3	1	2	Ethyl Cyanide	1	1	3	X	1	X
Dow Guard	1	1	1	1	1	1	Ethyl (Dibromide & Dichloride)	1	3	3	X	1	X
Dowtherm (A & E)	1	3	3	3	1	2	Ethyl Ether	1	2	2	3	3	2
Dowtherm, 209	1	3	1	3	3	3	Ethyl Formate	2	3	1	X	1	1
Drinking Water	1	1	1	1	1	1	Ethyl Hexanol	1	1	1	2	1	1
Dry Cleaning Fluids	2	3	3	3	1	2	Ethyl Isovalerate	1	X	X	X	X	X
DTE 20 Series, Mobil	1	2	3	3	1	2	Ethyl Mercaptan	1	3	X	3	2	X
DTE named series, Mobil, light-heavy	1	1	3	3	1	1	Ethyl (Lactate & Nitrite)	1	3	1	2	3	1
Elco 28-EP lubricant	1	1	3	2	1	1	Ethyl Oxalate	1	3	1	3	2	2
Epichlorohydrin	2	3	2	3	3	3	Ethyl (Pyridine, Stearate, & Valerate)	1	2	3	X	1	2
Epoxy Resins	1	X	1	X	3	X	Ethyl Pentachlorobenzene	1	3	3	3	1	2
Erucic Acid	1	X	X	X	X	X	Ethyl Silicate (TEOS)	1	1	1	X	1	1

Chemical Compatibility Table

1 = recommended
 2 = marginal
 3 = unsatisfactory
 X = insufficient data

Compound	Temperature Range	Compound	Temperature Range
Fluoroelastomer (FKM)	-26°C to 205°C (-15°F to 400°F)	Nitrile (NBR)	-34°C to 121°C (-30°F to 250°F)
Fluorosilicone (FVMQ)	-73°C to 190°C (-100°F to 375°F)	Ethylene Propylene (EPDM)	-57°C to 149°C (-70°F to 300°F)
Perfluoroelastomer (FFKM)	-26°C to 316°C (-15°F to 600°F)	Silicone (VMQ)	-54°C to 232°C (-65°F to 450°F)

ALWAYS TEST UNDER ACTUAL SERVICE CONDITIONS.

Published Temperature ranges will apply to majority of media for which the material is recommended.

Fluid	Perfluoroelastomer						Fluid	Perfluoroelastomer					
	Nitrile	Ethylene Propylene	Silicone	Fluoroelastomer	Fluorosilicone	Nitrile		Ethylene Propylene	Silicone	Fluoroelastomer	Fluorosilicone		
Ethyl Sulfate	X	X	1	X	3	X	Fluorinated Cyclic Ethers	1	X	1	X	X	X
Ethyl Tertiary Butyl Ether	1	3	3	X	2	X	Fluorobenzene	1	2	3	X	1	2
Ethylacrylic Acid	X	3	2	3	X	3	Fluoroboric Acid	1	1	1	X	X	X
Ethylamine	1	3	1	2	3	1	Fluorocarbon Oils	1	X	1	X	X	X
Ethylcyclopentane	1	1	3	3	1	1	Fluoroform (FC 23)	1	X	X	X	X	X
Ethylene (Ethylene Chloride)	1	3	3	3	2	2	Fluorolube	2	1	1	1	2	2
Ethylene Chlorohydrin	1	3	2	3	1	2	Fluorophosphoric Acid, Anhydrous	1	X	X	X	X	X
Ethylene Cyanohydrin	1	2	3	X	1	2	Fluorosilicic Acid	1	1	2	X	2	X
Ethylene (Dibromide & Dichloride)	1	3	3	3	1	3	Fluorosulfonic Acid	1	X	X	X	X	X
Ethylene Diamine	2	1	1	1	3	3	FOMBLIN	1	X	X	X	1	X
Ethylene (Hydrochloride, & Trichloride)	1	3	3	3	1	3	Formaldehyde	2	2	1	1	3	3
Ethylene Glycol	1	1	1	1	1	1	Formamide	1	3	1	2	3	1
Ethylene Glycol Butyl Ether	1	3	2	X	3	3	Formic Acid	2	2	1	2	3	X
Ethylene Glycol Butyl Ether Acetate	1	3	2	2	2	2	Freon 12	2	1	1	3	1	3
Ethylene Glycol Ethyl Ether Acetate (EGMEEA)	1	3	2	3	3	3	Freon (218 & C316)	2	1	1	X	1	X
Ethylene Oxide	1	3	1	3	3	X	Freon (K-142b & K-152a)	1	1	1	X	3	X
Ethylene Oxide ((12%) and Freon 12 (80%))	1	3	2	3	3	3	Freon 11	1	3	3	3	2	2
Ethylethoxy-3-Propionate (EEP)	1	X	X	X	X	X	Freon 112	2	2	3	3	1	X
Ethylhexyl Acrylate	1	X	X	X	X	X	Freon 113 + High and Low Aniline Oil	2	1	X	X	X	X
Ethylmorpholene Stannous Octotatate (50/50 mix)	1	3	2	X	3	X	Freon 114	X	1	1	3	1	X
Ethylmorpholine	1	2	3	X	1	2	Freon 114B2	2	2	3	3	2	X
Ethylsulfuric Acid	1	3	1	2	3	1	Freon (115 & 116)	2	1	1	X	2	X
F-60 Fluid (Dow Corning)	1	1	1	3	1	1	Freon (12, ASTM Oil #2(50/50 Mixture))	2	2	3	3	1	2
F-61 Fluid (Dow Corning)	1	1	1	3	1	1	Freon (Suniso 4G(50/50 Mixture))	2	2	3	3	1	2
Fatty Acids	1	2	3	3	1	X	Freon 13	2	1	1	3	1	3
FC-43 Heptacosofluorotri-butylamine	3	1	1	1	1	1	Freon 134a (Tetrafluoroethane)	1	X	1	X	X	X
FC75 & FC77 (Fluorocarbon)	3	1	1	1	2	2	Freon 13B1	2	1	1	3	1	2
Ferric (Acetate & Ammonium Sulfate)	1	3	1	2	3	1	Freon 14	1	1	1	3	1	X
Ferric (Ferrocyanide, & Hydroxide)	1	3	1	2	3	1	Freon 142b	2	2	3	X	2	X
Ferric Chloride	1	1	1	2	1	1	Freon 21	1	3	3	3	3	X
Ferric Nitrate	1	1	1	2	1	1	Freon 22 and ASTM Oil #2 (50/50 Mixture)	1	3	3	3	2	2
Ferrous Ammonium Citrate	1	3	1	2	3	1	Freon 31	2	3	1	X	3	X
Ferrous (Ammonium Sulfate, & Carbonate)	1	3	1	2	3	1	Freon 32	1	1	1	X	3	X
Ferrous (Iodide, Sulfate, & Tartrate)	1	3	1	2	3	1	Freon 502	2	2	1	X	2	X
Fish Oil	1	2	3	X	1	2	Freon BF	2	2	3	3	1	X
Fisher Reagent	X	X	2	X	X	X	Freon C318	2	1	1	X	2	X

Chemical Compatibility Table

1 = recommended
 2 = marginal
 3 = unsatisfactory
 X = insufficient data

Compound	Temperature Range	Compound	Temperature Range
Fluoroelastomer (FKM)	-26°C to 205°C (-15°F to 400°F)	Nitrile (NBR)	-34°C to 121°C (-30°F to 250°F)
Fluorosilicone (FVMQ)	-73°C to 190°C (-100°F to 375°F)	Ethylene Propylene (EPDM)	-57°C to 149°C (-70°F to 300°F)
Perfluoroelastomer (FFKM)	-26°C to 316°C (-15°F to 600°F)	Silicone (VMQ)	-54°C to 232°C (-65°F to 450°F)

ALWAYS TEST UNDER ACTUAL SERVICE CONDITIONS.

Published Temperature ranges will apply to majority of media for which the material is recommended.

Fluid	Perfluoroelastomer						Fluid	Perfluoroelastomer					
	Nitrile	Ethylene Propylene	Silicone	Fluoroelastomer	Fluorosilicone	Nitrile		Ethylene Propylene	Silicone	Fluoroelastomer	Fluorosilicone		
Freon MF	X	2	3	3	2	X	Glycerophosphoric Acid	1	3	1	2	3	1
Freon PCA	2	1	3	3	2	X	Glyceryl Phosphate	1	3	1	2	3	1
Freon TA	2	1	2	X	3	X	Glycidol	1	3	1	2	3	1
Freon TC	2	1	2	X	1	X	Glycolic Acid	1	3	1	2	3	1
Freon TF	X	1	3	3	2	X	Glycols	1	1	1	1	1	1
Freon TMC	2	2	3	X	1	X	Glyoxylic Acid	1	3	1	2	3	1
Freon T-P35	2	1	1	X	1	X	Grease Petroleum Base	X	1	3	3	1	1
Freon T-WD602	2	2	2	X	1	X	Green Sulfate Liquor	2	2	1	X	1	2
Fuel Oil	1	1	3	3	1	1	Gulf (Endurance Oils & FR Fluids (Emulsion))	1	1	3	3	1	1
Fuel Oil, #6	X	2	3	1	1	1	Gulf Harmony Oils	1	1	3	3	1	1
Fuel Oil (1 & 2)	X	1	3	3	1	1	Gulf (High Temp. Grease, & Legion Oils)	1	1	3	3	1	1
Fuel Oil, Acidic	X	1	3	1	1	1	Gulf (Paramount Oils & Security Oils)	1	1	3	3	1	1
Fumaric Acid	1	1	2	2	1	1	Gulf FR G-Fluids	X	1	1	1	1	1
Fuming Sulphuric Acid (20/25% Oleum)	1	3	3	3	1	X	Gulf FR P-Fluids	X	3	2	1	2	2
Furaldehyde	2	3	2	X	3	X	Gulfcrown Grease	X	1	3	3	1	1
Furan (Furfuran)	1	3	3	X	1	X	Halothane (Bromochlorotrifluoroethane)	2	3	3	3	1	2
Furfural (Furfuraldehyde)	1	3	1	3	3	X	Halowax Oil	2	3	3	3	1	1
Furfuryl Alcohol	1	3	2	3	X	3	Hannifin Lube A	X	1	3	2	1	1
Furyl Carbinol	1	3	2	3	X	3	Heavy Water	1	1	1	1	X	1
Furoic Acid	1	X	X	X	X	X	HEF-2 (High Energy Fuel)	1	2	3	3	1	2
Fyrquel	1	3	1	1	1	3	Helium	1	1	1	1	1	1
Fyrquel (150, 220, 300, & 550)	1	3	1	1	1	2	Heplane	X	1	3	3	1	1
Fyrquel (90, 100, & 500)	1	3	1	X	1	X	Hepta- (chlor & chlorobutene)	1	2	3	X	1	2
Fyrquel a60	1	3	2	X	3	X	Heptaldehyde (Heptanal)	1	1	3	2	1	1
GALDEN	3	X	X	X	1	X	Heptane or n-Heptane	1	1	3	3	1	3
Gallic Acid	1	1	1	X	1	1	Heptanoic Acid	1	1	3	2	1	1
Gasoline	1	1	3	3	1	1	Hexachloroacetone	1	3	1	2	3	1
Gelatin	1	1	1	1	1	1	Hexachloro- (butadiene, butene, & ethane)	1	2	3	X	1	2
Germanium Tetrahydride	1	X	X	X	X	X	Hexaldehyde or n-Hexaldehyde	1	3	1	2	3	3
Girling Brake Fluid	X	3	1	X	3	3	Hexaethyl Tetrphosphate (HETP)	1	X	X	X	X	X
Glauber's Salt	1	3	2	X	1	1	Hexafluoroethane (FC 116)	2	1	1	X	2	X
Gluconic Acid	1	3	1	2	3	1	Hexamethyldisilizane (HMDS)	1	X	X	X	X	X
Glucose	1	1	1	1	1	1	Hexamethylene (Cyclohexane)	2	1	3	2	1	1
Glutamic Acid	1	3	1	2	3	1	Hexamethylene- (diamine & tetramine)	1	3	1	2	3	1
Glycerine (Glycerol)	1	1	1	1	1	1	Hexamethylene Diammonium Adipate	1	2	3	X	1	2
Glycerol Dichlorohydrin	1	3	1	2	3	1	Hexane or n-Hexane	1	1	3	3	1	3
Glycerol (Monochlorohydrin, & Triacetate)	1	3	1	2	3	1	Hexanol	X	1	2	1	1	X

Chemical Compatibility Table

1 = recommended
 2 = marginal
 3 = unsatisfactory
 X = insufficient data

Compound	Temperature Range	Compound	Temperature Range
Fluoroelastomer (FKM)	-26°C to 205°C (-15°F to 400°F)	Nitrile (NBR)	-34°C to 121°C (-30°F to 250°F)
Fluorosilicone (FVMQ)	-73°C to 190°C (-100°F to 375°F)	Ethylene Propylene (EPDM)	-57°C to 149°C (-70°F to 300°F)
Perfluoroelastomer (FFKM)	-26°C to 316°C (-15°F to 600°F)	Silicone (VMQ)	-54°C to 232°C (-65°F to 450°F)

ALWAYS TEST UNDER ACTUAL SERVICE CONDITIONS.

Published Temperature ranges will apply to majority of media for which the material is recommended.

Fluid	Perfluoroelastomer						Fluid	Perfluoroelastomer					
	Nitrile	Ethylene Propylene	Silicone	Fluoroelastomer	Fluorosilicone	Nitrile		Ethylene Propylene	Silicone	Fluoroelastomer	Fluorosilicone		
Hexene-1 or n-Hexene-1	1	2	3	3	1	3	Hydrogen Chloride, Anhydrous	1	3	1	X	1	X
Hexone (Methyl Isobutyl Ketone)	1	3	1	2	3	1	Hydrogen Chloride gas	X	3	1	X	1	X
Hexyl Acetate	1	1	3	2	1	1	Hydrogen Fluoride (Anhydrous)	2	3	1	X	3	3
Hexyl Alcohol	1	1	3	2	1	2	Hydrogen Gas (Cold & Hot)	1	1	1	3	1	3
Hexylene Glycol	1	3	1	2	3	1	Hydrogen Iodide, Anhydrous	1	X	X	X	X	X
Hexylresorcinol	1	2	3	X	1	2	Hydrogen Peroxide	X	1	1	1	1	1
High Viscosity Lubricant (H2 & U4)	1	1	1	1	1	2	Hydrogen Peroxide (36%)	1	2	1	2	1	2
HiLo MS #1	X	3	1	3	3	3	Hydrogen Peroxide 90%	1	3	3	2	1	2
Home Heating Oil	X	1	3	1	1	X	Hydrogen Selenide	1	X	X	X	X	X
Houghto-Safe 271 (Water & Glycol Base)	X	1	1	2	2	2	Hydrogen Sulfide Dry Cold	1	1	1	3	3	3
Houghto-Safe 416 & 500 Series	X	1	1	X	X	X	Hydrogen Sulfide (Dry Hot, Wet Cold & Hot)	1	3	1	3	3	3
Houghto-Safe 620 Water/Glycol	X	1	1	2	2	2	Hydrolube-Water/Ethylene Glycol	1	1	1	2	1	2
Houghto-Safe 1010 phosphate ester	X	3	1	3	1	2	Hydroxycitronellal	1	X	X	X	1	2
Houghto-Safe 1055 phosphate ester	X	3	1	3	1	2	Hydroxyethylenediamine	1	X	X	X	X	X
Houghto-Safe 1120 phosphate ester	X	3	2	3	1	2	Hydroquinol	X	3	3	X	1	X
Houghto-Safe 5040 (Water/Oil emulsion)	X	1	3	3	1	2	Hydroquinone	2	2	3	X	1	2
Hydraulic Oil (Petroleum Base, Industrial)	1	1	3	2	1	1	Hydroxyacetic Acid	1	3	1	2	3	1
Hydraulic Oils (Synthetic Base)	1	2	3	X	1	2	Hydrene	2	2	1	3	3	3
Hydrazine	2	2	1	2	3	3	Hyjet (Hyjet (s4 & w)	1	3	1	X	3	X
Hydrazine (Anhydrous)	1	3	2	X	3	3	Hyjet IV and IVA	1	3	1	3	3	3
Hydrazine (Dihydrochloride & Hydrate)	1	3	1	2	3	1	Hypochlorous Acid	1	3	2	X	1	X
Hydriodic Acid	1	2	3	X	1	2	Hypoid Gear Lube	X	1	3	2	1	X
Hydrobromic (Acid & Acid 40%)	1	3	1	3	1	3	Indole	1	X	X	X	1	2
Hydrocarbons, Saturated	1	1	3	3	1	1	Industron (FF44, FF48, FF53, & FF80)	1	1	3	3	1	1
Hydrochloric Acid	1	1	1	3	1	3	Insulin	1	3	1	2	3	1
Hydrochloric Acid (cold) 37%	1	3	3	X	1	X	Iodic Acid	1	3	1	2	3	1
Hydrochloric Acid (hot) 37%	1	3	3	X	1	2	Iodine	1	1	1	X	1	1
Hydrochloric Acid, 3 Molar to 158°F	X	2	1	3	1	3	Iodine Pentafluoride	2	3	3	3	3	3
Hydrochloric Acid, (Conc. Room Temp.)	1	2	2	X	1	X	Iodoform	1	X	3	X	1	2
Hydrochloric Acid, Concentrated to 158°F	X	3	3	3	1	3	Iso Octane	1	1	3	3	1	1
Hydrocyanic Acid	1	1	1	2	1	3	Iso Phorone	1	3	1	3	3	2
Hydro-Drive MIH-10 & MIH-50	X	1	3	2	1	1	Isoamyl (Acetate, Butyrate, & Valerate)	1	3	1	2	3	1
Hydrofluoric Acid (49%)	1	3	3	3	1	3	Isoboreol	1	X	X	X	1	2
Hydrofluoric Acid (conc.) Hot	1	3	3	X	3	X	Isobutane	1	1	3	2	1	1
Hydrofluorosilicic Acid	1	2	1	3	1	3	Isobutene	1	X	X	X	X	X
Hydrogen	1	1	1	3	1	3	Isobutyl (Acetate, Methyl Ketone, & Phosphate)	1	3	1	2	3	1
Hydrogen Bromide, Anhydrous	1	X	X	X	X	X	Isobutyl Acrylate	1	X	X	X	X	X

Chemical Compatibility Table

1 = recommended
 2 = marginal
 3 = unsatisfactory
 X = insufficient data

Compound	Temperature Range	Compound	Temperature Range
Fluoroelastomer (FKM)	-26°C to 205°C (-15°F to 400°F)	Nitrile (NBR)	-34°C to 121°C (-30°F to 250°F)
Fluorosilicone (FVMQ)	-73°C to 190°C (-100°F to 375°F)	Ethylene Propylene (EPDM)	-57°C to 149°C (-70°F to 300°F)
Perfluoroelastomer (FFKM)	-26°C to 316°C (-15°F to 600°F)	Silicone (VMQ)	-54°C to 232°C (-65°F to 450°F)

ALWAYS TEST UNDER ACTUAL SERVICE CONDITIONS.

Published Temperature ranges will apply to majority of media for which the material is recommended.

Fluid	Material						Fluid	Material					
	Perfluoroelastomer	Nitrile	Ethylene Propylene	Silicone	Fluoroelastomer	Fluorosilicone		Perfluoroelastomer	Nitrile	Ethylene Propylene	Silicone	Fluoroelastomer	Fluorosilicone
Isobutyl Alcohol	1	2	1	1	1	2	Keystone #87HX-Grease	X	1	3	3	1	1
Isobutyl Chloride	1	3	3	X	1	X	Lacquer Solvents	1	3	3	3	3	3
Isobutyl Ether	1	2	3	X	3	X	Lactams-Amino Acids	1	3	2	X	3	3
Isobutyl n-Butyrate	1	3	1	X	1	1	Lactic Acid Cold	1	1	1	1	1	1
Isobutylene	1	X	X	X	1	2	Lactic Acid Hot	1	3	3	2	1	2
Isobutyraldehyde	2	3	2	X	3	X	Lactones (Cyclic Esters)	X	3	2	2	3	3
Isobutyric Acid	1	1	2	2	3	X	Lard Animal Fat	1	1	2	2	1	1
Isocrotyl Chloride	1	X	X	X	1	2	Lactic Acid	1	1	1	X	1	1
Isocyanate	X	X	X	X	1	X	Lauric Acid	1	1	3	2	1	1
Isodecanol	1	1	3	2	1	1	Lavender Oil	1	2	3	X	1	X
Isododecane	1	1	3	3	1	1	LB 135	X	1	1	X	1	X
Isoeugenol	1	1	3	2	1	1	Lead Acetate	1	2	1	3	3	3
Isooctane	1	1	3	3	1	1	Lead Azide	1	X	X	X	X	X
Isopar	X	1	3	3	1	X	Lead (Arsenate, Bromide, Carbonate, Chloride)	1	3	1	2	3	1
Isopentane	1	1	3	2	1	1	Lead (Chromate, Dioxide, Linoleate, & Oxide)	1	3	1	2	3	1
Isophorone (Ketone)	1	3	2	3	3	3	Lead Naphthenate	1	X	X	X	X	X
Isopropanol	1	1	1	1	1	1	Lead Nitrate	1	1	1	2	X	1
Isopropylacetone	1	3	1	2	3	1	Lead Sulfamate	1	2	1	2	1	1
Isopropylamine	1	3	1	2	3	1	Lehigh (X1169 & X1170)	X	1	3	3	1	1
Isopropyl Acetate	1	3	2	3	3	2	Light Grease	X	1	3	X	1	X
Isopropyl Alcohol (IPA)	1	2	1	1	1	2	Ligroin (Petroleum Ether or Benzene)	1	1	3	3	1	1
Isopropyl Chloride	1	3	3	3	1	2	Lime Bleach	1	1	1	X	1	X
Isopropyl Ether	1	2	3	3	3	3	Lime Sulfur	1	X	X	X	1	2
Isovaleric Acid	1	X	X	X	X	X	Lindol, Hydraulic Fluid (Phosphate ester type)	1	3	1	3	2	3
Jet Fuel A	1	2	3	X	1	2	Linoleic Acid	1	1	3	1	1	X
JIS Lube Oil #1	1	X	X	X	X	X	Linseed Oil	1	1	2	1	1	1
JP-10	1	3	3	3	1	1	Liquid Oxygen (LOX)	2	3	3	3	3	3
JP-3 (MIL-J-5624)	1	1	3	X	1	X	Liquid Petroleum Gas (LPG)	1	1	3	3	1	3
JP-4 (MIL-J-5624)	1	1	3	3	1	2	Liquimoly	X	1	3	3	1	1
JP-5 (MIL-J-5624)	1	1	3	3	1	2	Liquor	1	1	1	X	1	X
JP-6 (MIL-J-25656)	1	1	3	3	1	2	Lithium (Bromide (Brine), Carbonate, Chloride)	1	3	1	2	3	1
JP-8 (MIL-T-83133)	1	1	3	3	1	2	Lithium (Citrate, & Hydroxide)	1	3	1	2	3	1
JP-9 (MIL-F-81912) & (-11)	1	3	3	3	1	2	Lithium (Hypochlorite, Nitrate, & Nitrite)	1	3	1	2	3	1
JP-10	1	3	3	3	1	1	Lithium (Perchlorate, & Salicylate)	1	3	1	2	3	1
JPX (MIL-F-25604)	1	1	3	X	3	X	Lithopone	1	3	1	2	3	1
Kel F Liquids	3	1	1	1	2	2	Lubricating Oils (Crude & Refined)	X	2	3	X	1	X
Kerosene (Similar to RP-1 and JP-1)	1	1	3	3	1	1	Lubricating Oils (Synthetic base)	1	X	X	X	1	2

Chemical Compatibility Table

1 = recommended
 2 = marginal
 3 = unsatisfactory
 X = insufficient data

Compound	Temperature Range	Compound	Temperature Range
Fluoroelastomer (FKM)	-26°C to 205°C (-15°F to 400°F)	Nitrile (NBR)	-34°C to 121°C (-30°F to 250°F)
Fluorosilicone (FVMQ)	-73°C to 190°C (-100°F to 375°F)	Ethylene Propylene (EPDM)	-57°C to 149°C (-70°F to 300°F)
Perfluoroelastomer (FFKM)	-26°C to 316°C (-15°F to 600°F)	Silicone (VMQ)	-54°C to 232°C (-65°F to 450°F)

ALWAYS TEST UNDER ACTUAL SERVICE CONDITIONS.

Published Temperature ranges will apply to majority of media for which the material is recommended.

Fluid	Perfluoroelastomer						Fluid	Perfluoroelastomer					
	Nitrile	Ethylene Propylene	Silicone	Fluoroelastomer	Fluorosilicone	Nitrile		Ethylene Propylene	Silicone	Fluoroelastomer	Fluorosilicone		
Lubricating Oils Di-ester	1	2	3	3	1	2	Methacrylic Acid	1	3	1	2	3	1
Lubricating Oils (petroleum base)	1	1	3	3	1	1	Methyl Chloride	1	X	X	X	1	2
Lubricating Oils (SAE 10, 20, 30, 40, 50)	1	1	3	3	1	1	Methane	1	1	3	3	1	2
Lye Solutions	1	1	1	1	1	2	Methanethiol	1	X	X	X	X	X
m-Chloroaniline	1	3	2	X	3	X	Methanol	1	1	1	1	3	1
m-Chlorobenzotrifluoride	1	3	3	3	1	2	Methoxyethanol (DGMMA)	X	3	1	2	3	1
Magnesium (Chloride & Salts)	1	1	1	1	1	1	Methoxychlor	1	X	X	X	X	X
Magnesium Hydroxide	1	2	1	X	1	X	Methyl Acetate	1	3	1	3	3	3
Magnesium (Sulfite & Sulfate)	1	1	1	1	1	1	Methyl Acetoacetate	1	3	2	2	3	3
Malathion	1	1	3	3	1	2	Methyl Acrylate	1	3	2	3	3	3
Maleic Acid	1	3	3	X	1	X	Methyl Abietate	1	X	X	X	1	2
Maleic Anhydride	1	3	2	X	3	X	Methyl (Acetophenone, & Anthranilate)	1	X	X	X	1	2
Maleic Hydrazide	1	3	1	2	3	1	Methyl (amine & amyl Acetate)	X	3	1	2	3	1
Malic Acid	1	1	2	2	1	1	Methyl (glycerol, & sulfuric Acid)	X	3	1	2	3	1
Mandelic Acid	1	3	1	2	3	1	Methylal	1	X	X	X	X	X
Manganese (Acetate, Carbonate, Gluconate)	1	3	1	2	3	1	Methylallyl Chloride	1	X	X	X	X	X
Manganese Chloride	X	3	1	2	3	1	Methyl Alcohol	1	3	1	1	3	1
Manganese (Hypophosphite & Linoleate)	1	3	1	2	3	1	Methylamine	1	X	X	X	X	X
Manganese (Phosphate, & Sulfate)	1	3	1	2	3	1	Methylamyl Acetate	1	X	X	X	X	X
Manganous (Chloride, Phosphate, & Sulfate)	1	3	1	2	3	1	Methyl Amylketone	1	3	1	2	3	1
Mannitol	1	3	1	2	3	1	Methylamyl Alcohol	1	X	X	X	X	X
MCS (352 & 463)	X	3	1	3	3	3	Methylbenzyl Alcohol	1	X	X	X	X	X
MCS 312	X	3	3	1	1	1	Methyl Benzoate	1	3	3	3	1	1
MDI (Methylene di-p-phenylene isocyanate)	1	3	1	2	3	1	Methyl Bromide	1	2	3	X	1	1
Mercaptan	1	1	3	2	1	1	Methyl Butyl Ketone	1	3	1	3	3	3
Mercaptobenzothiazole (MBT)	1	X	X	X	1	2	Methyl Butyrate (Cellosolve & Chloride)	1	3	1	2	3	1
Mercuric (Acetate, Cyanide, & Iodide)	1	3	1	2	3	1	Methyl (Carbonate, Chloride, & Chloroformate)	1	3	3	3	1	2
Mercuric (Nitrate, Sulfate, & Sulfite)	1	3	1	2	3	1	Methyl Cellosolve	1	2	1	3	3	3
Mercuric Chloride	1	1	1	X	1	X	Methyl Cellulose	1	2	2	2	3	3
Mercurous Nitrate	1	3	1	2	3	1	Methyl Chloroform	1	3	3	X	1	X
Mercury	1	1	1	X	1	X	Methyl Chlorosilane	1	X	X	X	X	X
Mercury (Chloride, Fulminate, & Salts)	1	3	1	2	3	1	Methyl (Chloroacetate & Cyanide (Acetonitrile))	1	3	1	2	3	1
Mercury Vapors	1	1	1	X	1	X	Methyl Cyclohexanone	1	1	3	2	1	1
Mesityl Oxide (Ketone)	1	3	2	3	3	3	Methyl Ether	1	1	3	1	1	1
Meta- (Cresol & Toluidine)	1	X	X	X	1	2	Methyl Ethyl Ketone (MEK)	1	3	1	3	3	3
Meta-Nitroaniline	1	3	1	2	3	1	Methyl Ethyl Ketone Peroxide	1	3	3	2	3	3
Metaldehyde	1	3	1	2	3	1	Methyl Formate	1	3	2	X	X	X

Chemical Compatibility Table

1 = recommended
 2 = marginal
 3 = unsatisfactory
 X = insufficient data

Compound	Temperature Range	Compound	Temperature Range
Fluoroelastomer (FKM)	-26°C to 205°C (-15°F to 400°F)	Nitrile (NBR)	-34°C to 121°C (-30°F to 250°F)
Fluorosilicone (FVMQ)	-73°C to 190°C (-100°F to 375°F)	Ethylene Propylene (EPDM)	-57°C to 149°C (-70°F to 300°F)
Perfluoroelastomer (FFKM)	-26°C to 316°C (-15°F to 600°F)	Silicone (VMQ)	-54°C to 232°C (-65°F to 450°F)

ALWAYS TEST UNDER ACTUAL SERVICE CONDITIONS.

Published Temperature ranges will apply to majority of media for which the material is recommended.

Fluid							Fluid						
	Perfluoroelastomer	Nitrile	Ethylene Propylene	Silicone	Fluoroelastomer	Fluorosilicone		Perfluoroelastomer	Nitrile	Ethylene Propylene	Silicone	Fluoroelastomer	Fluorosilicone
Methyl Iodide	1	1	3	2	1	1	MIL-G-25013	X	1	1	3	1	1
Methyl Isobutyl Ketone (MIBK)	1	3	3	3	3	3	MIL-G-25537	X	1	3	3	1	1
Methyl Isopropyl Ketone	1	3	2	3	3	3	MIL-G-25760	X	2	3	3	1	2
Methyl (Dichloride, Ethyl Oleate, & Isovalerate)	1	X	X	X	1	2	MIL-G-3278	X	2	3	3	1	2
Methyl (Hexyl Ketone 2-Octanone Isocyanate)	1	3	1	2	3	1	MIL-G-3545	X	1	3	3	1	1
Methyl Lactate	1	3	1	2	3	1	MIL-G-4343	X	2	3	3	1	1
Methyl Mercaptan	1	X	1	X	X	X	MIL-G-5572	X	1	3	3	1	1
Methyl Methacrylate	1	3	3	3	3	3	MIL-G-7118	X	2	3	3	1	1
Methyl Oleate	1	3	2	X	1	2	MIL-G-7187	X	1	3	3	1	1
Methyl (Pentadiene, Phenylacetate, & Valerate)	1	X	X	X	1	2	MIL-G-7421	X	2	3	3	1	2
Methyl Salicylate	1	3	2	X	X	X	MIL-G-7711	X	1	3	2	1	1
Methylsulfuric Acid	1	X	X	X	X	X	MIL-H-13910	X	1	1	3	1	2
Methyl Tertiary Butyl Ether (MTBE)	1	3	3	X	3	X	MIL-H-19457	X	3	2	3	1	3
Methyl-2-Pyrrolidone or n-Methyl-2-Pyrrolidone	1	X	2	X	X	X	MIL-H-22251	X	2	1	3	X	X
Methylacrylic Acid	X	3	2	3	3	3	MIL-H-27601	X	1	3	3	1	2
Methylcyclopentane	1	3	3	3	1	2	MIL-H-46170 (-20°F to +275°F)	X	1	3	3	1	1
Methylene (Bromide & Iodide)	1	X	X	X	1	2	MIL-H-46170 ((-55°F to +275°F)	X	1	3	3	1	1
Methylene Chloride	1	3	3	3	1	2	MIL-H-5606 (-65°F to +235°F)	X	1	3	3	1	1
Methylisobutyl Carbinol	1	1	3	2	1	1	MIL-H-6083	X	1	3	3	1	1
Methylpyrrolid- (ine & one)	1	X	X	X	1	2	MIL-H-7083	X	1	1	1	2	1
MIL-A-6091	X	2	1	1	1	1	MIL-H-8446 (MLO-8515)	1	2	3	3	1	1
MIL-C-4339	X	1	3	3	1	1	MIL-J-5161	X	2	3	3	1	1
MIL-C-7024	X	1	3	3	1	1	MIL-L- 6085 & 7808	1	2	3	3	1	2
MIL-C-8188	X	2	3	3	2	2	MIL-L-15016 & 15017	X	1	3	3	1	2
MIL-E-9500	X	1	1	1	1	1	MIL-L-17331	X	1	3	3	1	X
MIL-F-16884	X	1	3	3	1	1	MIL-L-2104 & 21260	X	1	3	3	1	1
MIL-F-17111	X	1	3	3	1	2	MIL-L-23699	1	2	3	3	1	2
MIL-F-25558 (RJ-1)	1	1	3	3	1	1	MIL-L-25681	X	2	1	3	1	2
MIL-F-25656 (JP-6)	X	1	3	3	1	2	MIL-L-3150	X	1	3	3	1	1
MIL-F-5566	X	2	1	1	1	1	MIL-L-6081 & 6082	X	1	3	3	1	1
MIL-F-81912 (JP-9)	1	3	3	3	1	2	MIL-L-6387	X	2	3	3	1	2
MIL-F-82522 (RJ-4)	1	2	3	3	1	1	MIL-L-7808 LUBRICANTS	1	2	3	3	1	2
MIL-G-10924	X	1	3	3	1	1	MIL-L-7870	X	1	3	3	1	1
MIL-G-15793	X	1	3	3	1	2	MIL-L-9000	X	1	3	3	1	2
MIL-G-21568	X	1	1	3	1	1	MIL-L-9236	X	2	3	3	1	2

Chemical Compatibility Table

1 = recommended
 2 = marginal
 3 = unsatisfactory
 X = insufficient data

Compound	Temperature Range	Compound	Temperature Range
Fluoroelastomer (FKM)	-26°C to 205°C (-15°F to 400°F)	Nitrile (NBR)	-34°C to 121°C (-30°F to 250°F)
Fluorosilicone (FVMQ)	-73°C to 190°C (-100°F to 375°F)	Ethylene Propylene (EPDM)	-57°C to 149°C (-70°F to 300°F)
Perfluoroelastomer (FFKM)	-26°C to 316°C (-15°F to 600°F)	Silicone (VMQ)	-54°C to 232°C (-65°F to 450°F)

ALWAYS TEST UNDER ACTUAL SERVICE CONDITIONS.

Published Temperature ranges will apply to majority of media for which the material is recommended.

Fluid	Material						Fluid	Material					
	Perfluoroelastomer	Nitrile	Ethylene Propylene	Silicone	Fluoroelastomer	Fluorosilicone		Perfluoroelastomer	Nitrile	Ethylene Propylene	Silicone	Fluoroelastomer	Fluorosilicone
MIL-O-3503	X	1	3	3	1	1	Monochloroacetic Acid	X	3	1	2	3	1
MIL-P-27402	X	2	1	3	X	X	Monoethanolamine (MEA)	X	3	2	2	3	3
MIL-R-25576 (RP-1)	1	1	3	3	1	1	Mono- (ethyl Amine, & isopropylamine)	X	3	1	2	3	1
MIL-S-3136, Type I Fuel	1	1	3	3	1	1	Mono- (methylamine (MMA) & nitrotoluene)	X	3	1	2	3	1
MIL-S-3136 (Type II Fuel & Type III Fuel)	1	2	3	3	1	2	Monomethyl Aniline	1	3	1	2	2	1
MIL-S-3136 Type IV Oil High Swell	1	1	3	2	1	1	Monomethyl Ether (Methyl Ether)	X	1	3	X	1	X
MIL-S-3136 Type IV Oil Low Swell	1	1	3	3	1	1	Monomethyl Hydrazine	2	2	1	3	X	X
MIL-S-3136 Type V Oil Medium Swell	1	1	3	2	1	1	Monomethylaniline	X	3	2	X	2	X
MIL-S-81087	X	1	1	3	1	2	Mononitrotoluene (Dinitrotoluene (40/60 Mix)	X	3	1	3	3	3
MIL-T-5624, JP-4, JP-5	1	1	3	3	1	2	Monovinyl Acetylene	1	1	1	1	1	X
MIL-T-83133	1	1	3	3	1	2	Mopar Brake Fluid	1	3	1	3	3	3
Milk	1	1	1	1	1	1	Morpholine	1	X	X	X	1	2
Mineral Oil	1	1	2	1	1	1	Motor Oils	1	1	3	2	1	1
Mineral Spirits	X	1	3	3	1	X	Mustard	X	X	1	1	1	X
Mixed Acids	1	3	1	2	3	1	Myristic Acid	1	X	X	X	1	2
MLO- (7277 Hydr. & 7557)	1	3	3	3	1	3	Naphtha	1	1	3	3	1	2
MLO-8200 Hydr.	1	2	3	3	1	2	Naphthalene	1	3	3	3	1	1
MLO-8515	1	2	3	3	1	1	Naphthalene (Chloride & Sulfonic Acid)	1	X	X	X	1	2
Mobil (24dte, Delvac 1100, 1110, 1120, 1130)	1	1	3	X	1	X	Naphthalenic Acid	1	X	X	X	1	2
Mobil (Gas WA200 ATF, Oil SAE 20, & ux)	X	1	3	X	1	X	Naphthenic Acid	1	1	3	3	1	1
Mobil (Therm 600 & Velocite c)	1	1	3	X	1	X	Naphthylamine	1	X	X	X	X	X
Mobil HF	1	1	3	X	1	X	Naphtha	1	2	3	3	1	2
MOBILJET II Lubricant	1	X	X	X	X	X	Natural Gas	1	1	3	1	1	2
Mobil Nivac 20, 30	1	1	1	X	1	X	Neatsfoot Oil	1	1	1	1	1	1
Mobil SHC 500 Series	X	3	3	2	1	2	Neon	1	1	1	1	1	1
Mobil SHC 600 Series	X	3	3	3	1	2	Neville Acid	1	3	2	3	1	2
Mobilgear 600 Series	X	3	3	1	1	1	Niacinamide	1	X	X	X	X	X
Mobilgear SHC ISO Series	X	3	3	1	1	1	Nickel (Acetate, Ammonium Sulfate, & Nitrate)	1	2	1	3	3	3
Mobilgrease (HP, HTS, & SM)	X	2	3	2	1	1	Nickel (Chloride & Salts)	1	1	1	1	1	1
Mobilith AW Series	X	2	3	2	1	1	Nickel Sulfate	1	1	1	1	1	1
Mobilith SHC Series	X	2	3	2	1	1	Nicotinamide (Niacinamide)	1	X	X	X	1	2
Mobilmistlube Series	X	3	3	1	1	1	Nicotinamide Hydrochloride	1	3	1	2	3	1
Molybdenum (Oxide & Trioxide)	1	3	1	2	3	1	Nicotine	1	X	X	X	1	2
Molybdenum Disulfide Grease	1	1	3	X	1	X	Nicotine Sulfate	1	3	1	2	3	1
Molybdic Acid	1	3	1	2	3	1	Niter Cake	1	1	1	1	1	1
Mono- (bromobenzene & chlorobenzene)	X	3	3	3	1	2	Nitric Acid - Red Fuming	1	3	3	X	2	X
Mono- (bromotoluene & chlorobutene)	X	X	X	X	1	2	Nitric Acid (50 - 100%)	1	3	3	X	3	X

Chemical Compatibility Table

1 = recommended
 2 = marginal
 3 = unsatisfactory
 X = insufficient data

Compound	Temperature Range	Compound	Temperature Range
Fluoroelastomer (FKM)	-26°C to 205°C (-15°F to 400°F)	Nitrile (NBR)	-34°C to 121°C (-30°F to 250°F)
Fluorosilicone (FVMQ)	-73°C to 190°C (-100°F to 375°F)	Ethylene Propylene (EPDM)	-57°C to 149°C (-70°F to 300°F)
Perfluoroelastomer (FFKM)	-26°C to 316°C (-15°F to 600°F)	Silicone (VMQ)	-54°C to 232°C (-65°F to 450°F)

ALWAYS TEST UNDER ACTUAL SERVICE CONDITIONS.

Published Temperature ranges will apply to majority of media for which the material is recommended.

Fluid	Material						Fluid	Material					
	Perfluoroelastomer	Nitrile	Ethylene Propylene	Silicone	Fluoroelastomer	Fluorosilicone		Perfluoroelastomer	Nitrile	Ethylene Propylene	Silicone	Fluoroelastomer	Fluorosilicone
Nitric Acid 3 Molar to 158°F	X	3	2	3	3	3	Octyl Chloride or n-Octyl Chloride	1	1	3	2	1	1
Nitric Acid Concentrated Room Temp.	X	X	3	X	2	X	Octyl Phthalate	1	X	X	X	1	2
Nitric Acid Concentrated to 158°F	X	3	3	3	3	3	Olefins	1	X	X	X	1	2
Nitroaniline or p-Nitroaniline	1	3	1	2	3	1	Oleic Acid	1	2	3	3	1	X
Nitrobenzene	1	3	1	3	2	3	Oleum	1	1	3	3	1	X
Nitro- (benzoic Acid, cellulose, & chlorobenzene)	1	3	1	2	3	1	Oleum (Fuming Sulfuric Acid)	1	3	3	3	1	X
Nitro- (chloroform, & diethylaniline)	1	3	1	2	3	1	Oleum Spirits	X	2	3	3	1	2
Nitroethane	1	3	2	3	3	3	Oleyl Alcohol	1	X	X	X	1	2
Nitrofluorobenzene	1	3	1	2	3	1	Olive Oil	1	1	2	3	1	1
Nitroisopropylbenzene	X	3	1	2	3	1	Oronite (8200 & 8515)	X	2	3	3	1	1
Nitrogen Dioxide	1	X	X	X	3	X	Ortho- (Chloro Ethyl Benzene, Dichlorobenzene)	1	3	3	3	1	2
Nitrogen Trifluoride	1	X	X	X	X	X	Ortho- (Chloroaniline & Chlorophenol)	1	3	1	2	3	1
Nitro- (glycerine, glycerol, thiophene, & toluene)	1	3	1	2	3	1	Ortho- (Cresol, & Nitrotoluene)	1	3	1	2	3	1
Nitromethane	1	3	2	3	3	3	OS 45 (Type III (OS45), Type IV (OS45-1), OS70)	X	2	3	3	1	2
Nitrophenol or p-Nitrophenol	1	3	1	2	3	1	Oxalic Acid	1	1	1	1	1	1
Nitropropane	1	3	1	3	3	3	Oxygen, 200-300°F (Evaluate for specific apps)	1	3	3	X	2	X
Nitrogen	1	1	1	1	1	1	Oxygen, 300-400°F (Evaluate for specific apps)	1	3	3	1	2	3
Nitrogen Oxides	1	3	1	2	3	1	Oxygen, Cold (Evaluate for specific apps)	1	2	1	1	1	1
Nitrogen Tetroxide (N2O4)	2	3	3	3	3	3	Oxygen, Liquid	2	3	3	X	3	X
Nitrosyl Chloride	1	X	X	X	X	X	Ozonated Deionized Water	1	3	1	2	3	1
Nitrosylsulphuric Acid	1	X	X	X	X	X	Ozone	1	3	1	1	1	1
o-Nitrotoluene or p-Nitrotoluene	1	X	X	X	X	X	Paint Thinner, Duco	1	3	3	3	2	2
Nitrous Acid	1	3	1	2	3	1	Palmitic Acid	1	1	2	3	1	1
Nitrous Oxide	1	1	1	1	1	X	Para- (Aminobenzoic & Aminosalicic Acid)	X	3	1	2	3	1
Nonane	1	1	3	2	1	1	Para- Chlorophenol	X	3	1	2	3	1
Noryl GE Phenolic	X	1	1	X	X	X	Para Formaldehyde	1	3	1	2	3	1
Nyvac FR200 Mobil	X	1	1	X	1	X	Para- (Nitroaniline & Nitrobenzoic Acid)	1	3	1	2	3	1
Octachlorotoluene	1	3	3	3	1	2	Para- (Nitrophenol, & Toluene Sulfonic Acid)	1	3	1	2	3	1
Octadecane or n-Octadecane	1	1	3	3	1	1	Paracymene	X	X	X	X	1	2
Octafluorocyclobutane	2	X	1	X	2	X	Para-Dichlorobenzene	1	3	3	3	1	2
Octafluoropropane	2	X	X	X	X	X	Paraffins	1	1	3	2	1	1
Octanal (n-Octanaldehyde)	1	1	3	2	1	1	Paraldehyde	1	3	1	2	3	1
Octane or n-Octane	1	1	3	3	1	2	Par-al-Ketone	2	3	3	3	3	3
Octanol	1	1	1	1	1	X	Parathion	1	X	X	X	1	2
Octyl Acetate or n-Octyl Acetate	1	3	1	2	3	1	Parker O Lube	X	1	3	2	1	1
Octyl Alcohol or n-Octyl Alcohol	1	2	3	2	1	2	Peanut Oil	1	1	2	1	1	1

Chemical Compatibility Table

1 = recommended
 2 = marginal
 3 = unsatisfactory
 X = insufficient data

Compound	Temperature Range	Compound	Temperature Range
Fluoroelastomer (FKM)	-26°C to 205°C (-15°F to 400°F)	Nitrile (NBR)	-34°C to 121°C (-30°F to 250°F)
Fluorosilicone (FVMQ)	-73°C to 190°C (-100°F to 375°F)	Ethylene Propylene (EPDM)	-57°C to 149°C (-70°F to 300°F)
Perfluoroelastomer (FFKM)	-26°C to 316°C (-15°F to 600°F)	Silicone (VMQ)	-54°C to 232°C (-65°F to 450°F)

ALWAYS TEST UNDER ACTUAL SERVICE CONDITIONS.

Published Temperature ranges will apply to majority of media for which the material is recommended.

Fluid	Material						Fluid	Material					
	Perfluoroelastomer	Nitrile	Ethylene Propylene	Silicone	Fluoroelastomer	Fluorosilicone		Perfluoroelastomer	Nitrile	Ethylene Propylene	Silicone	Fluoroelastomer	Fluorosilicone
Pectin (Liquor)	1	X	X	X	1	2	Phosphine	1	X	X	X	X	X
Pelargonic Acid	1	X	X	X	X	X	Phosphoric Acid	1	1	1	1	1	2
Penicillin (Liquid)	1	X	X	X	1	2	Phosphoric Acid 3 Molar to 158°F	1	1	1	2	1	2
Pentachloroethane	1	X	X	X	1	2	Phosphoric Acid Concentrated Room Temp	1	2	1	3	1	3
Penta- (chlorophenol & erythritol)	1	3	1	2	3	1	Phosphoric Acid Concentrated to 158°F	1	3	1	3	1	3
Pentaerythritol Tetranitrate	1	3	1	2	3	1	Phosphoric Etchants	1	X	X	X	X	X
Pentafluoroethane (FC 125)	2	X	X	X	X	X	Phosphorous, Molten	1	X	X	X	X	X
Pentane or n-Pentane	1	1	3	3	1	3	Phosphorous Oxychloride	1	X	X	X	X	X
Pentane (2 Methyl, 2-4 Dimethyl, & 3 Methyl)	X	1	3	3	1	3	Phosphorous Tribromide	1	X	X	X	X	X
Pentyl Pentanoate	1	1	3	2	1	1	Phosphorous Trichloride	1	3	1	X	1	1
Peracetic Acid	1	3	1	2	3	1	Phthalic (Acid & Anhydride)	1	3	1	2	3	1
Perchloroethylene	1	1	3	3	1	2	Pickling Solution	1	3	3	3	2	3
Perchloric Acid - 2N	1	3	1	2	1	1	Picric Acid (aq)	1	1	1	X	1	2
Perchloroethylene	1	2	3	3	1	2	Picric Acid Molten	1	2	2	3	1	2
Petrolatum	1	1	3	3	1	1	Pine Oil	1	1	3	3	1	1
Petrolatum Ether	1	1	3	2	1	1	Pine Tar	1	1	3	2	1	1
Petroleum Ether	X	3	3	3	1	X	Pinene	1	2	3	3	1	1
Petroleum Oil, Above 250°F	1	3	3	3	2	3	Piperazine	1	X	X	X	1	2
Petroleum Oil, Below 250°F	1	1	3	2	1	2	Piperidine	1	3	3	3	1	2
Petroleum Oil, Crude	1	1	3	3	1	1	Piranha	1	X	X	X	X	X
Phenetole	1	3	3	3	3	3	Plating Solution Co,Cu,Au,In,Fe,Pb,Ni,Ag,Sn,Zn	1	1	1	X	1	X
Phenol	1	3	3	3	1	2	Plating Solutions Chrome	1	3	2	2	1	2
Phenol (70%/30% H2O) & (85%/15% H2O)	1	3	3	3	1	2	Plating Solutions Others	1	1	1	3	1	X
Phenyl Ethyl Ether	1	3	3	3	3	3	Pneumatic Service	X	1	1	3	1	3
Phenolic Sulfonate	1	3	1	2	3	1	Polyethylene Glycol	1	2	1	X	3	X
Phenolsulfonic Acid	1	3	1	2	3	1	Polyglycerol	1	3	1	2	3	1
Phenyl- (acetate, acetic Acid & glycerine)	1	3	1	2	3	1	Polyglycol	1	3	1	2	3	1
Phenyl- (hydrazine Hydrochloride, & mercuric Acetate)	1	3	1	2	3	1	Polyvinyl Acetate Emulsion	1	X	1	X	X	X
Phenylacetamide	1	X	X	X	1	2	Potassium Acetate	1	2	1	3	3	3
Phenylbenzene	1	3	3	3	1	2	Potassium (Acid Sulfate & Alum)	1	3	1	2	3	1
Phenylenediamine	1	X	X	X	X	X	Potassium (Aluminum Sulfate, & Antimonate)	1	3	1	2	3	1
Phenylethyl (Alcohol & Malonic Ester)	1	X	X	X	1	2	Potassium (Bicarbonate, Bichromate, Bifluoride)	1	3	1	2	3	1
Phenylethyl Ether	1	3	3	3	3	3	Potassium (Bisulfate, Bisulfite, Bitartrate, Bromide)	1	3	1	2	3	1
Phenylhydrazine	1	3	2	X	1	X	Potassium (Carbonate, Chlorate, & Chromates)	1	3	1	2	3	1
Phorone	1	3	3	3	3	3	Potassium (Citrate, Cyanate, & Diphosphate)	1	3	1	2	3	1
Phosgene	1	X	X	X	X	X	Potassium (Chloride, Cupro Cyanide, & Cyanide)	1	1	1	1	1	1

Chemical Compatibility Table

1 = recommended
 2 = marginal
 3 = unsatisfactory
 X = insufficient data

Compound	Temperature Range	Compound	Temperature Range
Fluoroelastomer (FKM)	-26°C to 205°C (-15°F to 400°F)	Nitrile (NBR)	-34°C to 121°C (-30°F to 250°F)
Fluorosilicone (FVMQ)	-73°C to 190°C (-100°F to 375°F)	Ethylene Propylene (EPDM)	-57°C to 149°C (-70°F to 300°F)
Perfluoroelastomer (FFKM)	-26°C to 316°C (-15°F to 600°F)	Silicone (VMQ)	-54°C to 232°C (-65°F to 450°F)

ALWAYS TEST UNDER ACTUAL SERVICE CONDITIONS.

Published Temperature ranges will apply to majority of media for which the material is recommended.

Fluid	Material						Fluid	Material					
	Perfluoroelastomer	Nitrile	Ethylene Propylene	Silicone	Fluoroelastomer	Fluorosilicone		Perfluoroelastomer	Nitrile	Ethylene Propylene	Silicone	Fluoroelastomer	Fluorosilicone
Potassium Dichromate	1	1	1	1	1	1	Propylene (Chloride, Chlorohydrin, Dichloride)	1	X	X	X	1	2
Potassium (Ferricyanide, Fluoride, Glucocyanate)	1	3	1	2	3	1	Propylene Glycol	1	3	1	2	3	1
Potassium Hydroxide	1	1	1	2	3	2	Propylene Glycol Methyl Ether Acetate	1	X	X	X	X	X
Potassium Hydroxide 50%	X	2	1	3	3	3	Propylene Oxide	1	3	2	3	3	3
Potassium (Hypochlorite, Iodate, & Iodide)	1	3	1	2	3	1	PRS-3000	1	X	2	2	2	2
Potassium (Metabisulfate & Metachromate)	1	3	1	2	3	1	Pydraul (230C, 312C, 540C, & A200)	2	3	3	3	1	3
Potassium Molten	3	X	X	X	X	X	Pydraul (29ELT 30E, 50E, & 65E)	1	3	1	1	1	1
Potassium Monochromate	1	3	1	2	3	1	Pydraul 115E	2	3	1	3	1	3
Potassium (Nitrate, Salts, Sulfate, & Sulfite)	1	1	1	1	1	1	Pydraul 90e	1	3	1	X	1	X
Potassium (Nitrite, Oxalate, & Perchlorate)	1	3	1	2	3	1	Pydraul, 10E	1	3	1	1	3	3
Potassium (Permanganate, & Persulfate)	1	3	1	2	3	1	Pyranol	X	1	3	1	1	3
Potassium Peroxide	1	X	X	X	X	X	Pyranol Transformer Oil	1	1	3	3	1	1
Potassium Phosphate (Acid & Alkaline)	1	3	1	2	3	1	Pyridine	1	3	2	X	1	2
Potassium Phosphate (Di/Tri Basic)	1	3	1	2	3	1	Pyridine (Sulfate & Sulfonic Acid)	1	3	1	2	3	1
Potassium (Pyrosulfate & Sodium Tartrate)	1	3	1	2	3	1	Pyridine Oil	X	3	2	3	3	3
Potassium (Stannate, Stearate, & Sulfide)	1	3	1	2	3	1	Pyrogallol (Pyrogallic Acid)	1	2	3	X	1	2
Potassium Silicate	1	X	X	X	X	X	Pyrogard 42, 43, 55	1	3	1	X	1	X
Potassium (Tartrate & Thiocyanate)	1	3	1	2	3	1	Pyrogard 53, Mobil Phosphate Ester	1	3	1	3	1	3
Potassium (Thiosulfate, & Triphosphate)	1	3	1	2	3	1	Pyrogard D, Mobil Water-in-Oil Emulsion	X	1	3	3	3	2
Prestone Antifreeze	1	1	1	1	1	1	Pyroligneous Acid	1	3	2	X	3	3
PRL-High Temp. Hydr. Oil	1	2	3	2	1	1	Pyrolube	1	3	2	2	1	2
Producer Gas	1	1	3	2	1	2	Pyrosulfuric Acid	1	3	1	2	3	1
Propane	1	1	3	3	1	2	Pyrosulfuryl Chloride	1	2	3	X	1	2
Propanol	X	1	1	1	1	X	Pyrrrole	1	3	3	2	3	3
Propionaldehyde	1	3	1	2	3	1	Pyruvic Acid	1	3	1	2	3	1
Propionic Acid	1	3	1	2	3	1	Quinidine	1	2	3	X	1	2
Propionitrile	1	1	3	X	1	X	Quinine	1	2	3	X	1	2
Propyl Acetate or n-Propyl Acetate	1	3	2	3	3	3	Quinine (Bisulfate, Hydrochloride, Sulfate, & Tartrate)	1	3	1	2	3	1
Propyl Acetone or n-Propyl Acetone	1	3	1	3	3	3	Quinizarin & Quinoline	1	2	3	X	1	2
Propyl Alcohol	1	1	1	1	1	1	Quinone	1	2	3	X	1	2
Propyl Nitrate or n-Propyl Nitrate	1	3	2	3	3	3	Radiation (GAMMA, 1.0 E+07 RADS)	2	3	2	2	3	3
Propyl Propionate or n-Propyl Propionate	1	3	1	2	3	1	Raffinate	1	2	3	X	1	2
Propylamine or n-Propylamine	2	3	1	2	3	1	Rapeseed Oil	1	1	3	1	1	3
Propylbenzene & n-Propylbenzene	1	X	X	X	1	2	Red (Line 100 Oil & Oil (MIL-H-5606))	1	1	3	3	1	1
Propylene	1	3	3	3	1	3	Resorcinol	1	3	1	2	3	1

Chemical Compatibility Table

1 = recommended
 2 = marginal
 3 = unsatisfactory
 X = insufficient data

Compound	Temperature Range	Compound	Temperature Range
Fluoroelastomer (FKM)	-26°C to 205°C (-15°F to 400°F)	Nitrile (NBR)	-34°C to 121°C (-30°F to 250°F)
Fluorosilicone (FVMQ)	-73°C to 190°C (-100°F to 375°F)	Ethylene Propylene (EPDM)	-57°C to 149°C (-70°F to 300°F)
Perfluoroelastomer (FFKM)	-26°C to 316°C (-15°F to 600°F)	Silicone (VMQ)	-54°C to 232°C (-65°F to 450°F)

ALWAYS TEST UNDER ACTUAL SERVICE CONDITIONS.

Published Temperature ranges will apply to majority of media for which the material is recommended.

Fluid	Material						Fluid	Material					
	Perfluoroelastomer	Nitrile	Ethylene Propylene	Silicone	Fluoroelastomer	Fluorosilicone		Perfluoroelastomer	Nitrile	Ethylene Propylene	Silicone	Fluoroelastomer	Fluorosilicone
Rhodium	1	X	X	X	X	X	Silver Sulfate	1	3	1	2	3	1
Riboflavin	1	2	3	X	1	2	Sinclair Opaline CX-EP Lube	1	1	3	3	1	1
Ricinoleic Acid	1	2	3	X	1	2	Skelly Solvent	X	1	3	X	X	X
RJ-1 (MIL-F-25558)	1	1	3	3	1	1	Skelly, Solvent B, C, E	X	1	3	X	1	1
RJ-4 (MIL-F-82522)	1	2	3	3	1	1	Skydrol (500 B4 & LD-4)	1	3	1	3	3	3
Rosin	1	2	3	X	1	2	Skydrol 500	1	3	3	3	3	3
RP-1 (MIL-R-25576)	1	1	3	3	1	1	Skydrol 7000	1	3	1	X	2	X
Saccharin Solution	1	3	1	2	3	1	Soap Solutions	1	1	1	1	1	1
SAE 10W30	X	1	3	1	1	1	SoconyMobile Type A	X	1	3	3	1	2
Sal Ammoniac	1	1	1	2	1	1	Socony Vacuum AMV AC781 (grease)	X	1	3	3	1	2
Salicylic Acid	1	2	1	X	1	1	Socony Vacuum PD959B	1	1	3	3	1	1
Santo Safe 300	1	3	3	1	1	1	Sodium Abietate	1	X	X	X	X	X
Sea (Salt) Water	1	1	1	1	1	1	Sodium Acetate	1	2	1	3	3	3
Seawater	X	1	1	3	3	1	Sodium Acid (Bisulfate, Fluoride, & Sulfate)	1	3	1	2	3	1
Sebacic, Selenic & Selenous Acid	1	3	1	2	3	1	Sodium (Aluminate & Aluminate Sulfate)	1	3	1	2	3	1
Sewage	1	1	1	1	1	1	Sodium Anthraquinone Disulfate	1	3	1	2	3	1
1154 & 96 GE Silicone Fluid	X	2	1	3	1	1	Sodium (Antimonate, Aresenate & Arsenite)	1	3	1	2	3	1
SF 1147 GE Silicone Fluid	X	2	3	3	1	X	Sodium (Benzoate & Bichromate)	1	3	1	2	3	1
Shell 3XF Mine Fluid (Fire resist hydr.)	X	1	3	X	1	1	Sodium (Bifluoride, Bisulfide & Bitartrate)	1	3	1	2	3	1
Shell Alvania Grease #2	X	1	3	2	1	1	Sodium (Bromate & Bromide)	1	3	1	2	3	1
Shell Carnea 19 and 29	X	1	3	X	1	1	Sodium Bicarbonate (Baking Soda)	1	1	1	1	1	1
Shell Diala	X	1	3	3	1	1	Sodium (Bisulfate, Bisulfite & Borate)	1	1	1	1	1	1
Shell Irus 905	X	1	3	3	1	1	Sodium Carbonate (Soda Ash)	1	1	1	1	1	1
Shell (Lo Hydrax 27 and 29 & Macome 72)	X	1	3	3	1	1	Sodium (Chlorate, Chlorite & Chloroacetate)	1	1	1	1	1	1
Shell Tellus (#32 Pet. Base & #68)	X	1	3	3	1	1	Sodium (Chromate, Citrate, Cyanamide, Cyanate)	1	3	1	2	3	1
Shell Tellus (27 (Petroleum Base) & 33)	1	1	3	X	1	X	Sodium Chloride	1	1	1	1	1	X
Shell UMF (5% Aromatic)	1	1	3	3	1	1	Sodium Cyanide	1	1	1	1	X	X
Shellac	1	3	1	2	3	1	Sodium Dichromate	1	X	X	X	X	X
Silane	1	X	X	X	X	X	Sodium (Diacetate & Diphenyl Sulfonate)	1	3	1	2	3	1
Silicate Esters	1	2	3	3	1	1	Sodium (Diphosphate, Disilicate & Ethylate)	1	3	1	2	3	1
Silicone Grease	1	1	1	1	1	1	Sodium (Ferricyanide, Ferrocyanide & Fluoride)	1	3	1	2	3	1
Silicone Oils	1	1	1	3	1	3	Sodium (Fluorosilicate & Glutamate)	1	3	1	2	3	1
Silicon Tetrachloride	2	X	X	X	X	X	Sodium Hydride	1	X	X	X	X	X
Silicon Tetrafluoride	2	X	X	X	X	X	Sodium (Hydrogen Sulfate, Hydrosulfide-(fite)	1	3	1	2	3	1
Silver (Bromide, Chloride & Cyanide)	1	3	1	2	3	1	Sodium Hydroxide	1	1	1	3	1	1
Silver Nitrate	1	1	1	1	1	1	Sodium Hydroxide, 3 Molar	X	2	1	1	2	2
Silver Oxide	1	X	X	X	X	X	Sodium Hypochlorite	1	2	1	2	1	2

Chemical Compatibility Table

1 = recommended
 2 = marginal
 3 = unsatisfactory
 X = insufficient data

Compound	Temperature Range	Compound	Temperature Range
Fluoroelastomer (FKM)	-26°C to 205°C (-15°F to 400°F)	Nitrile (NBR)	-34°C to 121°C (-30°F to 250°F)
Fluorosilicone (FVMQ)	-73°C to 190°C (-100°F to 375°F)	Ethylene Propylene (EPDM)	-57°C to 149°C (-70°F to 300°F)
Perfluoroelastomer (FFKM)	-26°C to 316°C (-15°F to 600°F)	Silicone (VMQ)	-54°C to 232°C (-65°F to 450°F)

ALWAYS TEST UNDER ACTUAL SERVICE CONDITIONS.

Published Temperature ranges will apply to majority of media for which the material is recommended.

Fluid							Fluid						
	Perfluoroelastomer	Nitrile	Ethylene Propylene	Silicone	Fluoroelastomer	Fluorosilicone		Perfluoroelastomer	Nitrile	Ethylene Propylene	Silicone	Fluoroelastomer	Fluorosilicone
Sodium (Hypophosphate & Hypophosphite)	1	3	1	2	3	1	Stannous (Bromide, Fluoride, & Sulfate)	1	3	1	2	3	1
Sodium (Hyposulfite & Iodide)	1	3	1	2	3	1	Stannous Chloride (15%)	1	1	1	2	1	1
Sodium (Lactate & Metasilicate)	1	3	1	2	3	1	Stauffer 7700	1	2	3	3	1	2
Sodium (Methylate & Monophosphate)	1	3	1	2	3	1	Steam Below 400°F	1	3	1	3	3	3
Sodium Metaphosphate	1	1	1	X	1	1	Steam, 400°-500°F	2	3	3	3	3	3
Sodium Nitrate	1	2	1	3	X	X	Stearic Acid	1	1	1	X	X	1
Sodium (Oleate, Orthosilicate & Oxalate)	1	3	1	2	3	1	Stoddard Solvent (ASTM D-484-52)	1	1	3	3	1	1
Sodium (Percarbonate, Persulfate, & Phenolate)	1	3	1	2	3	1	Strontium (Acetate, Carbonate, & Chloride)	1	3	1	2	3	1
Sodium (Phenoxide, Plumbite, & Resinate)	1	3	1	2	3	1	Strontium (Hydroxide, & Nitrate)	1	3	1	2	3	1
Sodium (Phosphate (Dibasic) & (Mono))	1	1	1	3	1	X	Styrene (Monomer)	1	3	3	3	2	3
Sodium Perborate	1	2	1	2	1	1	Succinaldehyde	1	X	X	X	X	X
Sodium Peroxide	1	2	1	3	1	1	Succinic Acid	1	3	1	2	3	1
Sodium Phosphate (Tribasic)	1	1	1	1	1	X	Sucrose Solutions	1	1	1	1	1	1
Sodium (Salicylate, Stannate, & Sulfo cyanide)	1	3	1	2	3	1	Sulfamic Acid & Sulfanilic Acid	1	3	1	2	3	1
Sodium (Tartrate, & Tetraborate)	1	3	1	2	3	1	Sulfanilic Chloride	1	2	3	X	1	2
Sodium Salts	1	1	1	1	1	1	Sulfanilamide	1	2	3	X	1	2
Sodium Sesquisilicate	3	X	X	X	X	X	Sulfite Liquors	1	3	1	2	3	1
Sodium Silicate	1	1	1	X	1	X	Sulfolane	1	2	1	X	2	X
Sodium (Sulfate, Sulfide, & Sulfite)	1	1	1	1	1	1	Sulfonated Oils	X	2	3	X	1	2
Sodium (Tetraphosphate & Tetrasulfide)	1	3	1	2	3	1	Sulfonic Acid	1	3	1	2	3	1
Sodium (Thioarsenate, & Thiocyanate)	1	3	1	2	3	1	Sulfonyl Chloride	X	3	1	2	3	1
Sodium Thiosulfate	1	2	1	1	1	1	Sulfur	1	3	1	X	1	1
Sodium (Trichloroacetate & Triphosphate)	1	3	1	2	3	1	Sulfur (Molten)	X	3	3	3	1	3
Sorbitol	1	3	1	2	3	1	Sulfur Chloride	1	3	3	3	1	1
Sour (Crude Oil & Natural Gas)	1	3	3	3	1	3	Sulfur Dioxide (Dry & Liquidified w/ pressure)	1	3	1	2	3	2
Sovasol	X	1	3	1	1	3	Sulfur Dioxide, Wet	1	3	1	2	3	2
Sovasol No. 1, 2, and 3	1	1	3	3	1	1	Sulfur Hexafluoride	2	2	1	X	3	X
Sovasol No. 73 and 74	X	2	3	3	1	1	Sulfur Liquors	X	2	2	3	1	2
Soy Bean Oil	1	1	3	1	X	1	Sulfur, Molten	1	3	3	3	1	1
Spry	X	1	2	1	1	1	Sulfur Monochloride	1	1	3	2	1	1
SR-10 Fuel	X	1	3	3	1	1	Sulfur Tetrafluoride	2	X	X	X	X	X
SR-6 Fuel	1	2	3	3	1	1	Sulfur Trioxide Dry	1	3	2	2	1	2
Standard Clean 1 (SC - 1)	1	X	X	X	X	X	Sulfuric Acid (20% Oleum)	1	3	1	2	3	1
Standard Clean 2 (SC - 2)	1	X	X	3	X	3	Sulfuric Acid	1	1	1	1	3	3
Standard Oil Mobilube GX90-EP Lube	X	1	3	3	1	1	Sulfuric Acid, 3 Molar to 158°F	X	2	1	1	1	1
Stannic (Ammonium Chloride & Tetrachloride)	1	3	1	2	3	1	Sulfuric Acid, Concentrated Room Temp	1	X	3	X	1	X
Stannic (Chloride & Chloride (50%))	1	1	1	2	1	1	Sulfuric Acid, Concentrated to 158°F	X	3	3	3	1	3

Chemical Compatibility Table

1 = recommended
 2 = marginal
 3 = unsatisfactory
 X = insufficient data

Compound	Temperature Range	Compound	Temperature Range
Fluoroelastomer (FKM)	-26°C to 205°C (-15°F to 400°F)	Nitrile (NBR)	-34°C to 121°C (-30°F to 250°F)
Fluorosilicone (FVMQ)	-73°C to 190°C (-100°F to 375°F)	Ethylene Propylene (EPDM)	-57°C to 149°C (-70°F to 300°F)
Perfluoroelastomer (FFKM)	-26°C to 316°C (-15°F to 600°F)	Silicone (VMQ)	-54°C to 232°C (-65°F to 450°F)

ALWAYS TEST UNDER ACTUAL SERVICE CONDITIONS.

Published Temperature ranges will apply to majority of media for which the material is recommended.

Fluid	Material						Fluid	Material					
	Perfluoroelastomer	Nitrile	Ethylene Propylene	Silicone	Fluoroelastomer	Fluorosilicone		Perfluoroelastomer	Nitrile	Ethylene Propylene	Silicone	Fluoroelastomer	Fluorosilicone
Sulfuric Chlorohydrin (Chlorosulfonic Acid)	1	3	1	2	3	1	Texaco Regal B	X	1	3	3	1	1
Sulfurous Acid	1	2	2	3	1	X	Texaco Uni-Temp Grease	1	1	3	2	1	1
Sunoco (#3661, All purpose grease, & SAE 10)	1	1	3	3	1	1	Texamatic A (1581, 3401 & 3525 Fluid)	1	1	3	3	1	2
Sunsafe (Fire resist. hydr. fluid)	X	1	3	X	1	1	Texamatic A (3528 Fluid) & Transmission Oil)	X	1	3	3	1	2
Super Shell Gas	1	1	3	3	1	2	Texas 1500 Oil	X	1	3	2	1	1
Surfuryl Chloride	1	3	1	2	3	1	Therminol 44	X	3	3	3	1	X
Swan Finch EP Lube	1	1	3	3	1	1	Therminol 55	1	2	3	3	1	X
Swan Finch Hypoid-90	X	1	3	3	1	1	Therminol VP-1, 60, 65	X	3	3	2	1	X
Tail Oil	X	1	3	1	3	X	Thioamyl Alcohol	1	1	3	2	1	1
Tallow	1	1	3	2	1	1	Thio- (diacetic Acid, ethanol, & glycolic Acid)	1	3	1	2	3	1
Tannic Acid	1	1	1	3	X	1	Thiokol (TP-90B & TP-95)	1	3	1	X	1	2
Tannic Acid (10%)	1	1	1	2	1	1	Thionyl Chloride	1	2	3	X	1	2
Tar	1	1	3	3	X	1	Thiophene (Thiofuran)	1	2	3	X	1	2
Tar, bituminous	1	2	3	2	1	1	Thiophosphoryl Chloride	1	3	1	2	3	1
Tartaric Acid	1	1	1	X	X	1	Thiourea	1	3	1	2	3	1
Terephthalic Acid	1	3	1	2	3	1	Thorium Nitrate	1	3	1	2	3	1
Terpineol	1	2	3	X	1	1	Tidewater Multigear, 140 EP Lube	X	1	3	3	1	1
Terpinyl Acetate	1	2	3	X	1	2	Tidewater Oil	1	1	3	1	1	1
Tertiary Butyl Catechol (p)	1	3	2	X	1	1	Tidewater Oil-Beedol	X	1	3	2	1	1
Tertiary Butyl Mercaptan	1	3	3	X	1	X	Tin (Chloride & Tetrachloride)	1	1	3	2	1	1
Tetrabromomethane	1	2	3	X	1	2	Tin Ammonium Chloride	1	3	1	2	3	1
Tetrabutyl Titanate	1	2	1	3	1	3	Titanic Acid	1	3	1	2	3	1
Tetrachloroethylene	1	3	3	3	1	2	Titanium (Dioxide & Sulfate)	1	3	1	2	3	1
Tetrachoroethane	1	3	3	X	1	2	Titanium Tetrachloride	2	2	3	3	1	2
Tetraethyl Lead	1	2	3	X	1	2	Toluene	1	3	3	3	1	2
Tetraethyl Lead Blend	X	2	3	X	1	2	Toluene Diisocyanate (TDI)	1	3	2	3	3	3
TEOS (Tetraethylorthosilicate)	1	1	1	3	1	1	Toluene Sulfonyl Chloride	1	2	3	X	1	2
Tetrafluoroethane (FC 134a)	1	X	X	X	X	X	Toluenesulfonic Acid	1	3	1	2	3	1
Tetrafluoromethane (FC 14)	1	1	1	3	1	X	Toluidine or p-Toluidine	1	2	3	X	1	2
Tetrahydrofuran (THF)	1	3	2	3	3	3	Toluol	1	3	1	2	3	1
Tetralin (Tetrahydronaphthalene)	1	3	3	3	1	1	Toluquinone	1	2	3	X	1	2
Tetramethyl Ammonium Hydroxide	1	3	1	2	3	1	Tolylaldehyde or p-Tolylaldehyde	1	3	1	2	3	1
TMCTS (Tetramethylcyclotetrasiloxane)	1	X	X	X	X	X	Transformer Oil	1	1	3	2	1	1
Tetramethyldihydropyridine	1	2	3	X	1	2	Transmission Fluid Type A	1	1	3	2	1	1
Tetraphosphoglucosate	1	3	1	2	3	1	Triacetin	1	2	1	X	3	3
Texaco Capella A-AA & Meropa 220-No Lead	X	1	3	3	1	1	Triaryl Phosphate	1	3	1	3	1	2
Texaco 3450 Gear Oil	1	1	3	3	1	1	Tribromomethylbenzene	1	2	3	X	1	2

Chemical Compatibility Table

1 = recommended
 2 = marginal
 3 = unsatisfactory
 X = insufficient data

Compound	Temperature Range	Compound	Temperature Range
Fluoroelastomer (FKM)	-26°C to 205°C (-15°F to 400°F)	Nitrile (NBR)	-34°C to 121°C (-30°F to 250°F)
Fluorosilicone (FVMQ)	-73°C to 190°C (-100°F to 375°F)	Ethylene Propylene (EPDM)	-57°C to 149°C (-70°F to 300°F)
Perfluoroelastomer (FFKM)	-26°C to 316°C (-15°F to 600°F)	Silicone (VMQ)	-54°C to 232°C (-65°F to 450°F)

ALWAYS TEST UNDER ACTUAL SERVICE CONDITIONS.

Published Temperature ranges will apply to majority of media for which the material is recommended.

Fluid	Perfluoroelastomer						Fluid	Perfluoroelastomer					
	Nitrile	Ethylene Propylene	Silicone	Fluoroelastomer	Fluorosilicone	Nitrile		Ethylene Propylene	Silicone	Fluoroelastomer	Fluorosilicone		
Tributoxyethyl Phosphate	1	3	1	X	1	2	Trioctyl Phosphate	1	3	1	3	2	2
Tributylamine	1	X	X	X	X	X	Triphenylphosphite	1	3	1	2	3	1
Tributyl Citrate	1	3	1	2	3	1	Tripolyphosphate	X	3	1	3	2	1
Tributyl Mercaptan	1	3	3	3	1	3	Tripotassium Phosphate	1	3	1	2	3	1
Tributyl Phosphate	1	3	1	3	3	3	Trisodium Phosphate	1	3	1	2	3	1
Trichloroacetic Acid (TCA)	1	2	2	X	3	3	Tritium	1	X	X	X	X	X
Trichloroacetyl Chloride	1	2	3	X	1	2	Tung Oil (China Wood Oil)	1	1	3	3	1	2
Trichlorobenzene	1	2	3	X	1	2	Tungsten Hexafluoride	1	X	X	X	X	X
Trichloro- (ethane, ethylene (TCE), & methane)	1	3	3	3	1	2	Tungstic Acid	1	X	X	X	X	X
Trichloro- (propane, & silane)	1	3	3	3	1	2	Turbine Oil	1	1	3	3	1	1
Trichloroethanolamine	1	3	1	2	3	1	Turbine Oil #15 (MIL-L-7808A)	1	2	3	3	1	2
Trichlorofluoromethane (FC 11)	2	2	3	3	2	2	Turbo Oil #35	X	1	3	3	1	1
Trichloronitromethane (Chloropicrin)	1	3	1	2	3	1	Turpentine	1	1	3	1	3	3
Trichlorophenylsilane	1	X	X	X	X	X	Type I Fuel (MIL-S-3136)(ASTM Ref. Fuel A)	X	1	3	3	1	1
Trichlorotrifluoroethane (FC 113)	2	2	3	3	2	3	Type II Fuel MIL-S-3136	X	2	3	3	1	2
Tricresyl Phosphate	1	3	1	3	2	2	Type III Fuel MIL-S-3136 (ASTM Ref. Fuel B)	X	2	3	3	1	2
Triethanol Amine (TEA)	2	2	1	3	3	X	UCDN 50HB280X	X	1	1	X	X	1
Triethylaluminum	1	3	3	X	3	X	Ucon Hydrolube J-4	1	1	1	1	1	2
Triethylamine	1	X	X	X	X	X	Ucon Lubricant ((50-HB-100) & (50-HB-260))	1	1	1	1	1	1
Triethylborane	1	3	3	X	1	X	Ucon Lubricant (50-HB-5100)	1	1	1	1	1	1
Triethyl Borate	1	X	X	X	X	X	Ucon Lubricant ((50-HB-55), & (50-HB-660))	1	1	1	1	1	1
Triethyl Phosphate	1	2	3	X	1	2	Ucon Lubricant (LB-1145, LB-135, & LB-285)	1	1	1	1	1	1
Triethylene Glycol (TEG)	1	3	1	2	3	1	Ucon Lubricant (LB-300X, LB-625, & LB-65)	1	1	1	1	1	1
Triethylenetetramine (TETA)	1	3	1	2	3	1	Ucon Oil Heat Transfer 500	1	1	1	1	1	1
Trifluoroethane FC 143a	1	3	3	3	1	2	Ucon Oil (LB-385, & LB400X)	1	1	1	1	1	1
Trifluoromethane (Freon 23)	1	3	3	3	1	2	Ucon Oil 50-HB-280x	1	2	1	X	3	X
Trifluoroacetic Acid	2	3	1	2	3	1	Undecylenic Acid & Undecylic Acid	1	2	3	X	1	2
Trifluorovinylchloride	1	2	3	X	1	2	Univis 40 (Hydr. Fluid)	1	1	3	3	1	1
Triisopropylbenzylchloride	1	2	3	X	1	2	Univolt #35 (Mineral Oil)	1	1	3	3	1	1
Trimethyl- (benzene & borate (TMB))	1	2	3	X	1	2	Univs J-43	X	1	3	1	1	3
TMAI (Trimethylaluminum)	1	X	X	X	X	X	Unsymmetrical Dimethyl Hydrazine (UDMH)	2	2	1	3	3	3
Trimethylamine (TMA)	2	3	1	2	3	1	UPDI (Ultrapure Deionized Water)	1	3	1	2	3	1
Trimethylpentane	1	1	3	2	1	1	Uranium Hexachloride	2	X	X	X	1	X
Trimethylolpropane	1	X	X	X	X	X	Urea	1	X	X	X	X	X
TMP (Trimethyl Phosphite)	1	X	X	X	X	X	Uric Acid	1	3	1	2	3	1
TMPO (Trimethyl Phosphate)	1	X	X	X	X	X	Valeraldehyde or n-Valeraldehyde	1	3	1	2	3	1
Trinitrotoluene (TNT)	1	3	3	X	2	2	Valeric Acid	1	3	1	2	3	1

Chemical Compatibility Table

1 = recommended
 2 = marginal
 3 = unsatisfactory
 X = insufficient data

Compound	Temperature Range	Compound	Temperature Range
Fluoroelastomer (FKM)	-26°C to 205°C (-15°F to 400°F)	Nitrile (NBR)	-34°C to 121°C (-30°F to 250°F)
Fluorosilicone (FVMQ)	-73°C to 190°C (-100°F to 375°F)	Ethylene Propylene (EPDM)	-57°C to 149°C (-70°F to 300°F)
Perfluoroelastomer (FFKM)	-26°C to 316°C (-15°F to 600°F)	Silicone (VMQ)	-54°C to 232°C (-65°F to 450°F)

ALWAYS TEST UNDER ACTUAL SERVICE CONDITIONS.

Published Temperature ranges will apply to majority of media for which the material is recommended.

Fluid	Material						Fluid	Material					
	Perfluoroelastomer	Nitrile	Ethylene Propylene	Silicone	Fluoroelastomer	Fluorosilicone		Perfluoroelastomer	Nitrile	Ethylene Propylene	Silicone	Fluoroelastomer	Fluorosilicone
Vanadium (Oxide & Pentoxide)	1	1	3	2	1	1	Wolmar Salt	1	1	1	1	1	1
Varnish	1	1	3	3	2	3	Wood Alcohol (Methanol)	1	1	1	1	3	1
Vegetable Oil	1	1	3	1	1	1	Wood Oil	1	1	3	3	1	2
Versilube F44, F55	1	1	1	X	1	X	Xenon	1	1	1	1	1	1
Versilube F-50	1	1	1	3	1	1	Xylene	1	3	3	3	1	1
Vinegar	1	1	1	3	3	1	Xylidenes-Mixed-Aromatic Amines	1	3	1	3	3	3
Vinyl (Benzene, Benzoate, Chloride, Fluoride)	1	2	3	X	1	2	Xylol	1	3	3	3	1	1
Vinyl Acetate	1	2	1	X	3	X	Zeolites	1	1	1	X	1	1
Vinylidene Chloride	1	2	3	X	1	2	Zinc (Ammonium Chloride, Chromate, Cyanide)	1	3	1	2	3	1
Vinylpyridine	1	2	3	X	1	2	Zinc (Diethylthiocarbamate & Dihydrogen Phosphate)	1	3	1	2	3	1
Vitriol (White)	1	3	1	2	3	1	Zinc Fluorosilicate	1	X	X	X	X	X
VV-H-910	1	3	1	2	1	2	Zinc Naphthenate	1	X	X	X	X	X
Wagner 21B Brake Fluid	1	3	1	3	3	3	Zinc (Hydrosulfite, Phenolsulfonate, Stearate, & Sulfide)	1	3	1	2	3	1
Water	1	1	1	3	3	1	Zinc (Phosphate & Salts)	1	1	1	1	1	1
Wemco C	1	1	3	3	1	1	Zinc Acetate	1	2	1	3	3	3
Wheat Germ Oil	X	1	3	1	1	1	Zinc Chloride	1	1	1	X	1	1
Whiskey and Wines	1	1	1	1	1	1	Zinc (Nitrate & Oxide)	1	1	1	X	1	1
White Liquor	X	1	1	X	1	X	Zinc Sulfate	1	1	1	1	1	1
White Oil	1	1	3	3	1	1	Zirconium Nitrate	1	1	1	1	1	1
White Pine Oil	1	2	3	3	1	1							

The information provided within the Chemical Compatibility Table has been compiled from several sources and is believed to be reliable, but no representation, guarantees or warranties of any nature are being made to the accuracy or suitability for any purpose. The information is based on laboratory testing and does not indicate end-product performance. It is highly recommended that the end users conduct their own evaluations suitable for the intended application.

Please contact Bay Seal Company to assist with the selection of any compound.

Pressure Conversion Table

Millibar	Torr	Lb/in2 (PSI)	In Hg	atm	% Vacuum
1013	760.00	14.69	30.00	1.000	0.0
1000	750.00	14.50	29.61	0.987	1.3
981	735.75	14.23	29.05	0.968	3.2
900	675.00	13.05	26.65	0.888	11.1
800	600.00	11.60	23.69	0.789	21.0
700	525.00	10.15	20.73	0.691	30.9
600	450.00	8.70	17.77	0.592	40.8
500	375.00	7.25	14.81	0.494	50.6
400	300.00	5.80	11.85	0.395	60.5
300	225.00	4.35	8.884	0.296	70.4
200	150.00	2.90	5.923	0.197	80.2
100	75.00	1.45	2.961	0.099	90.1
90	67.50	1.31	2.665	0.089	91.1
80	60.00	1.16	2.369	0.079	92.1
70	52.50	1.02	2.073	0.069	93.1
60	45.00	0.870	1.777	0.059	94.1
50	37.50	0.725	1.481	0.049	95.1
40	30.00	0.580	1.185	0.040	96.1
30	22.50	0.435	0.8884	0.030	97.0
20	15.00	0.290	0.5923	0.020	98.0
10	7.50	0.145	0.2961	0.010	99.0
5	3.75	0.073	0.1480	5 x 10-3	99.5
1	0.75	0.015	0.0296	1 x 10-3	99.9
0.5	0.375	7.25 x 10-3	0.0148	5 x 10-4	99.99
0.1	0.075	1.45 x 10-3	2.96 x 10-3	1 x 10-4	99.99 +
0.01	7.5 x 10-3	1.45 x 10-4	2.96 x 10-4	1 x 10-5	99.99 +
1 x 10-3	7.5 x 10-4	1.45 x 10-5	2.96 x 10-5	1 x 10-6	99.99 +
1 x 10-4	7.5 x 10-5	1.45 x 10-6	2.96 x 10-6	1 x 10-7	99.99 +
1 x 10-6	7.5 x 10-7	1.45 x 10-8	2.96 x 10-8	1 x 10-9	99.99 +
1 x 10-7	7.5 x 10-8	1.45 x 10-9	2.96 x 10-9	1 x 10-10	99.99 +
1 x 10-8	7.5 x 10-9	1.45 x 10-10	2.96 x 10-10	1 x 10-11	99.99 +
0	0	0	0	0	100

Temperature Conversion Table

°C	°F	°C	°F	°C	°F	°C	°F	°C	°F	°C	°F
-273	-459.4	-20	-4	75	167	200	392	360	680	550	1022
-260	-436	-10	14	80	176	204	400	370	698	560	1040
-240	-400	0	32	85	185	210	410	380	716	570	1058
-220	-364	1	33.8	90	194	220	428	390	734	580	1076
-200	-328	5	41	95	203	230	446	400	752	590	1094
-180	-292	10	50	100	212	232	450	410	770	600	1112
-160	-256	15	59	107	225	240	464	420	788	610	1130
-140	-220	20	68	110	230	250	482	430	806	620	1148
-120	-184	23	73.4	120	248	260	500	440	824	630	1166
-100	-148	25	77	121	250	270	518	450	842	640	1184
-90	-130	30	86	130	266	280	536	460	860	650	1202
-80	-112	35	95	135	275	290	554	470	878	660	1220
-70	-94	40	104	140	284	300	572	480	896	670	1238
-57	-70	45	113	149	300	310	590	490	914	680	1256
-55	-67	50	122	150	302	316	600	500	932	690	1274
-54	-65	55	131	160	320	320	608	510	950	700	1292
-40	-40	60	140	170	338	330	626	520	968	710	1310
-34	-30	65	149	180	356	340	644	530	986	720	1328
-30	-22	70	158	190	374	350	662	540	1004	730	1346



COMMON SEAL FAILURES

ABRASION

Description: The seal or parts of the seal exhibit a flat surface parallel to the direction or motion. Loose particles and scrapes may be found on the seal surface.



Contributing Factors: Rough sealing surfaces. Excessive temperature. Process environment containing abrasive particles. Dynamic motion. Poor elastomer surface finish.

Suggested Solutions: Use recommended gland surface finish. Consider internally lubed elastomers. Eliminate abrasive components.

COMPRESSION SET

Description: The seal exhibits a flat-sided cross-section, the flat sides corresponding to the mating seal surfaces.



Contributing Factors: Excessive compression. Excessive temperature. Incompletely cured elastomer. Elastomer with high compression set. Excessive volume swell in chemical.

Suggested Solutions: Low compression set elastomer. Proper gland design for the specific elastomer. Confirm material compatibility.

CHEMICAL DEGRADATION

Description: The seal may exhibit many signs of degradation including blisters, cracks, voids or discoloration. In some cases, the degradation is observable only by measurement of physical properties.



Contributing Factors: Incompatibility with the chemical and/or thermal environment.

Suggested Solutions: Selection of more chemically resistant elastomer.

EXPLOSIVE DECOMPRESSION

Description: The seal exhibits blisters, pits or pocks on its surface. Absorption of gas at high pressure and the subsequent rapid decrease in pressure. The absorbed gas blisters and ruptures the elastomer surface as the pressure is rapidly removed.



Contributing Factors: Rapid pressure changes. Low-modulus/hardness elastomer.

Suggested Solutions: Higher-modulus/hardness elastomer. Slower decompression (release of pressure).

EXTRUSION

Description: The seal develops ragged edges (generally on the low-pressure side), which appear tattered.

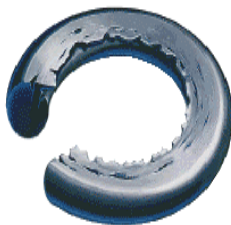

Contributing Factors: Excessive clearances. Excessive pressure. Low-modulus/hardness elastomer. Excessive gland fill. Irregular clearance gaps. Sharp gland edges. Improper sizing.

Suggested Solutions: Decrease clearances. Higher-modulus/hardness elastomer. Proper gland design. Use of polymer backup rings.

INSTALLATION DAMAGE

Description: The seal or parts of the seal may exhibit small cuts, nicks or gashes.



Contributing Factors: Sharp edges on glands or components. Improper sizing of elastomer. Low-modulus/hardness elastomer. Elastomer surface contamination.

Suggested Solutions: Remove all sharp edges. Proper gland design. Proper elastomer sizing. Higher-modulus/hardness elastomer.

COMMON SEAL FAILURES

OUTGASSING / EXTRACTION

Description: This failure is often very difficult to detect from examination of the seal. The seal may exhibit a decrease in cross-sectional size.



Contributing Factors: Improper or improperly cured elastomer. High vacuum levels. Low hardness/plasticized elastomer.

Suggested Solutions: Avoid plasticized elastomers. Ensure all seals are properly post-cured to minimize Outgassing.

OVERCOMPRESSION

Description: The seal exhibits parallel flat surfaces (corresponding to the contact areas) and may develop circumferential splits within the flattened surfaces.



Contributing Factors: Improper design—failure to account for thermal or chemical volume changes, or excessive compression.

Suggested Solutions: Gland design should take into account material responses to chemical and thermal environments.

PLASMA DEGRADATION

Description: The seal often exhibits discoloration, as well as powdered residue on the surface and possible erosion of elastomer in the exposed areas.



Contributing Factors: Chemical reactivity of the plasma. Ion bombardment (sputtering). Electron bombardment (heating). Improper gland design. Incompatible seal material.

Suggested Solutions: Plasma-compatible elastomer and compound. Minimize exposed area. Examine gland design.

SPIRAL FAILURE

Description: The seal exhibits cuts or marks which spiral around its circumference.



Contributing Factors: Difficult or tight installation (static). Slow reciprocating speed. Low-modulus/hardness elastomer. Irregular O-ring surface finish (including excessive parting line). Excessive gland width. Irregular or rough gland surface finish. Inadequate lubrication.

Suggested Solutions: Correct installation procedures. Higher-modulus elastomer. Internally lubed elastomers. Proper gland design. Gland surface finish of 8–16 micro inch RMS. Possible use of polymer backup rings.

THERMAL DEGRADATION

Description: The seal may exhibit radial cracks located on the highest temperature surfaces. In addition, certain elastomers may exhibit signs of softening—a shiny surface as a result of excessive temperatures.



Contributing Factors: Elastomer thermal properties. Excessive temperature excursions or cycling.

Suggested Solutions: Selection of an elastomer with improved thermal stability. Evaluation of the possibility of cooling sealing surfaces.



Standard Glossary Terms

Abrasion: The wearing away of a surface in service by mechanical action such as rubbing, scraping, or erosion.

Acid Resistance: Withstands the action of acids.

Adhesion: The tendency of rubber to bond or cling to a contact surface.

Compound: A term applied to a mixture of polymers and other ingredients, to produce a usable rubber material.

Compression Set: The amount by which a rubber specimen fails to return to original shape after release of compressive load.

Cross-Section: A seal as viewed if cut at right angles to the mold parting line showing internal structure.

Durometer: Measure of the hardness of rubber. Measures the resistance to the penetration of an indenter point into the surface of rubber. Numerical scale of rubber hardness.

Dynamic Seal: A seal required to prevent leakage past parts which are in relative motion.

Elastomer: Any synthetic or natural material with resilience or memory sufficient to return to its original shape after major or minor distortion.

Face Seal: A seal between two flat surfaces.

Friction: Resistance to motion due to the contact of surfaces.

Gland: Cavity into which an O-Ring is installed. Includes the groove and mating surface of second part, which together confine the O-Ring.

Hardness: Resistance to a distorting force. Measured by the relative resistance of the material to an indenter point of any one of a number of standard hardness testing instruments.

Memory: The tendency of a material to return to original shape after deformation.

O-Ring: A circle of material with round cross section, which affects a seal through squeeze and pressure.

O-Ring Seal: The combination of a gland and an O-Ring providing a fluid-tight closure.

Outgassing: A vacuum phenomenon wherein a substance spontaneously releases volatile constituents in the form of vapors and/or gases. Some constituents could include water vapor, plasticizers, air, and inhibitors.

Polymer: A material formed by the joining together of many individual units of one or more monomers.

Resilient: Capable of returning to original size and shape after deformation.

Shrinkage: Decreased volume of seal, usually caused by extraction of soluble constituents by fluids followed by air-drying.

Squeeze: Cross-section diametral compression of an O-Ring between surface of the groove bottom and the surface of another mating metal part in the gland assembly.

Static Seal: Part designed to seal between parts having no relative motion.

Swell: Increased volume of a specimen caused by immersion in a fluid (usually a liquid).

Temperature Range: Maximum and minimum temperature limits within which a seal compound will function in a given application.

Thermal Expansion: Expansion caused by increase in temperature. May be linear or volumetric.

Vacuum: A given space that is occupied by a gas at less than atmospheric pressure.

Volume Swell: Increases in physical size caused by the swelling action of a liquid.

Vulcanization: A thermo-setting reaction involving the use of heat and pressure, resulting in greatly increased strength and elasticity of rubber-like materials.

Guide

-70	-94	40	104	140	284	300	572	480	896	670	1238
-57	-70	45	113	149	300	310	590	490	914	680	1256
-55	-67	50	122	150	302	316	600	500	932	690	1274
-54	-65	55	131	160	320	320	608	510	950	700	1292
-40	-40	60	140	170	338	330	626	520	968	710	1310
-34	-30	65	149	180	356	340	644	530	986	720	1328
-30	-22	70	158	190	374	350	662	540	1004	730	1346

COMMON SEAL FAILURES

ABRASION

Description: The seal or parts of the seal exhibit a flat surface parallel to the direction or motion. Loose particles and scrapes may be found on the seal surface.

Contributing Factors: Rough sealing surfaces. Excessive temperature. Process environment containing abrasive particles. Dynamic motion. Poor elastomer surface finish.

Suggested Solutions: Use recommended gland surface finish. Consider internally lubed elastomers. Eliminate abrasive components.

COMPRESSION SET

Description: The seal exhibits a flattened cross-section, the flat side corresponding to the mating surfaces.

Contributing Factors: Excessive compression. Excessive temperature. Incompletely cured elastomer. Elastomer with high compression set. Excessive volume swell in chemical.

Suggested Solutions: Low compression set elastomer. Proper gland design for the specific elastomer. Confirm material compatibility.

CHEMICAL DEGRADATION

Description: The seal may exhibit many signs of degradation including blisters, cracks, voids or discoloration. In some cases, the degradation is observable only by measurement of physical properties.

Contributing Factors: Incompatibility with the chemical and/or thermal environment.

Suggested Solutions: Selection of more chemically resistant elastomer.

EXPLOSIVE DECOMPRESSION

Description: The seal exhibits blister pits or pocks on its surface. Absorption of gas at high pressure and the subsequent rapid decrease in pressure. The absorbed gas blisters and ruptures the elastomer surface as the pressure is rapidly removed.

Contributing Factors: Rapid pressure changes. Low-modulus/hardness elastomer.

Suggested Solutions: Higher-modulus/hardness elastomer. Slow decompression (release of pressure).

EXTRUSION

Description: The seal develops ragged edges (generally on the low-pressure side), which appear tattered.

INSTALLATION DAMAGE

Description: The seal or parts of the seal may exhibit small cuts, nicks or gashes.



Guide

Contributing Factors: Excessive clearances. Excessive pressure. Low-modulus/hardness elastomer. Excessive gland fill. Irregular clearance gaps. Sharp gland edges. Improper sizing.

Suggested Solutions: Decrease clearances. Higher-modulus/hardness elastomer. Proper gland design. Use of polymer backup rings.

Contributing Factors: Sharp edges of glands or components. Improper sizing of elastomer. Low-modulus/hardness elastomer. Elastomer surface contamination.

Suggested Solutions: Remove all sharp edges. Proper gland design. Proper elastomer sizing. Higher-modulus/hardness elastomer.

COMMON SEAL FAILURES

OUTGASSING / EXTRACTION

Description: This failure is often very difficult to detect from examination of the seal. The seal may exhibit a decrease in cross-sectional size.

Contributing Factors: Improper or improperly cured elastomer. High vacuum levels. Low hardness/plasticized elastomer.

Suggested Solutions: Avoid plasticized elastomers. Ensure all seals are properly post-cured to minimize Outgassing.

OVERCOMPRESSION

Description: The seal exhibits parallel flat surfaces (corresponding to the contact areas) and may develop circumferential splits within the flattened surfaces.

Contributing Factors: Improper design—failure to account for thermal or chemical volume changes, or excessive compression.

Suggested Solutions: Gland design should take into account material responses to chemical and thermal environments.

PLASMA DEGRADATION

Description: The seal often exhibits discoloration, as well as powdered residue on the surface and possible erosion of elastomer in the exposed areas.

Contributing Factors: Chemical reactivity of the plasma. Ion bombardment (sputtering). Electron bombardment (heating). Improper gland design. Incompatible seal material.

Suggested Solutions: Plasma-compatible elastomer and compound. Minimize exposed area. Examine gland design.

SPIRAL FAILURE

Description: The seal exhibits cuts or marks which spiral around its circumference.

Contributing Factors: Difficult or tight installation (static). Slow reciprocating speed. Low-modulus/hardness elastomer. Irregular O-ring surface finish (including excessive parting line). Excessive gland width. Irregular or rough gland surface finish. Inadequate lubrication.

Suggested Solutions: Correct installation procedures. Higher-modulus elastomer. Internally lubed elastomer. Proper gland design. Gland surface finish of 8–16 micro inch RMU. Possible use of polymer backup rings.

THERMAL DEGRADATION



Guide

Description: The seal may exhibit radial cracks located on the highest temperature surfaces. In addition certain elastomers may exhibit signs of softening—a shiny surface as a result of excessive temperatures.

Contributing Factors: Elastomer thermal properties. Excessive temperature excursions or cycling.

Suggested Solutions: Selection of an elastomer with improved thermal stability. Evaluation of the possibility of cooling sealing surfaces.



Standard Glossary Terms

Abrasion: The wearing away of a surface in service by mechanical action such as rubbing, scraping, or erosion.

Acid Resistance: Withstands the action of acids.

Adhesion: The tendency of rubber to bond or cling to a contact surface.

Compound: A term applied to a mixture of polymers and other ingredients, to produce a usable rubber material.

Compression Set: The amount by which a rubber specimen fails to return to original shape after release of compressive load.

Cross-Section: A seal as viewed if cut at right angles to the mold parting line showing internal structure.

Durometer: Measure of the hardness of rubber. Measures the resistance to the penetration of an indenter point into the surface of rubber. Numerical scale of rubber hardness.

Dynamic Seal: A seal required to prevent leakage past parts which are in relative motion.

Elastomer: Any synthetic or natural material with resilience or memory sufficient to return to its original shape after major or minor distortion.

Face Seal: A seal between two flat surfaces.

Friction: Resistance to motion due to the contact of surfaces.

Gland: Cavity into which an O-Ring is installed. Includes the groove and mating surface of second part, which together confine the O-Ring.

Hardness: Resistance to a distorting force. Measured by the relative resistance of the material to an indenter point of any one of a number of standard hardness testing instruments.

Memory: The tendency of a material to return to original shape after deformation.

O-Ring: A circle of material with round cross section, which affects a seal through squeeze and pressure.

O-Ring Seal: The combination of a gland and an O-Ring providing a fluid-tight closure.

Outgassing: A vacuum phenomenon wherein a substance spontaneously releases volatile constituents in the form of vapors and/or gases. Some constituents could include water vapor, plasticizers, air, and inhibitors.

Polymer: A material formed by the joining together of many individual units of one or more monomers.

Resilient: Capable of returning to original size and shape after deformation.

Shrinkage: Decreased volume of seal, usually caused by extraction of soluble constituents by fluids followed by air-drying.

Squeeze: Cross-section diametral compression of an O-Ring between surface of the groove bottom and the surface of another mating metal part in the gland assembly.

Static Seal: Part designed to seal between parts having no relative motion.

Swell: Increased volume of a specimen caused by immersion in a fluid (usually a liquid).

Temperature Range: Maximum and minimum temperature limits within which a seal compound will function in a given application.

Thermal Expansion: Expansion caused by increase in temperature. May be linear or volumetric.

Vacuum: A given space that is occupied by a gas at less than atmospheric pressure.

Volume Swell: Increases in physical size caused by the swelling action of a liquid.

Vulcanization: A thermo-setting reaction involving the use of heat and pressure, resulting in greatly increased strength and elasticity of rubber-like materials.





Whether your sealing application is standard or not, Bay Seal Company has the experience and knowledge to assist you with application and design review, material selection, seal and profile design, failure analysis, sampling & proto-typing, problem solving and recommendations.

www.bayseal.com

O-RINGS

- Teflon Seals
- Vacuum Seals
- Metal Seals
- Low Closure Force Seals
- O-Ring Kits
- Splicing Kits
- O-Ring Removal Tools
- O-Ring Measuring Cone



OTHER PRODUCTS

- Extrusions
- Lathe Cutting
- Rod & Piston Seals
- O-Ring Lube
- Vacuum Lube
- Adhesives
- Conductive Elastomers
- Gaskets



WE MANUFACTURE

- Seamless Spliced O-Rings
- Custom Molded Shapes
- Elastomer to Metal Bonding
- Elastomer to Teflon Bonding



Kalrez®



Vespel®



Zalak®





*Bay Seal Company:
Specializing in providing
cost effective, high quality
sealing solutions for our customers.*

our story

Bay Seal Company began in 1957 as a branch office of the Porter Seal Company. In 1972 we purchased the Hayward office and changed the name. In 1993 we opened our second office in Austin, Texas; Austin Seal. Since that time, our customers in Austin have experienced the same superior support and commitment that we have always provided Northern California. In 1998 we added Leonard's Molded Products to our family so that we had a direct supplier of custom products. Finally, in 2007 we added Southwest Seal and Supply into the fold to increase our presence in the southwest.

our commitment to you

Bay Seal, and all of our sister companies, will be extraordinary providers of highly engineered solutions and value added services in the markets we serve. We will use the talents of our employees and suppliers to provide world class products and services to you, our customers.



9400 Business Dr.
Austin, TX 78758
800.900.SEAL (7325)
Phone: 512.832.0047
Fax: 512.832.7220
www.austinseal.com



25847 Springbrook Ave
Santa Clarita, CA 91350
Phone: 661.253.2227
Fax: 661.253.1777
www.lmprubber.com



3825 Osuna Rd., NE, Suite 6
Albuquerque, NM 87109
Phone: 505.889.8828
Fax: 505.889.0804

10937 Pellicano Dr.
El Paso, TX 79935
Phone: 915.772.1775
Fax: 915.772.7161

7711 W. 6th Ave., Suite M
Lakewood, CO 80214
Phone: 303.761.1666
Fax: 303.761.3555
www.swseal.com



**1550 W. Winton Ave
Hayward, CA 94545**
800.273.SEAL (7325)
Phone: 510.732.7000
Fax: 510.782.2651

**Will Call Hours
Mon-Fri 8AM - 5PM**
www.bayseal.com